



Service Kit Part Number 10041218
 ConMet R-Drive Flat Rotor 10034621
 Rotor Minimum Thickness 1.46" (37 mm)



ConMet 10034621 Flat Rotor

DISC BRAKE ROTOR REPLACEMENT

NOTE

Install the brake rotor using only the hardware provided in the kit.

NOTE

If present, retain stainless steel insulator (see image below).

NOTE

*If Loctite® 272 is not available, use Loctite® 262.

1. If the rotor mounting studs were removed from the hub during disassembly, apply Loctite® 272* to the coarse end of the double-ended stud and to the rotor mounting threads in the hub. Install the studs.
2. Clean all mating surfaces.
3. Place the stainless steel insulator and the rotor on the hub.
4. Install and torque the rotor mounting nuts in a star pattern to 200 ft-lbs.
5. Place the ABS tone ring on the rotor.
6. Install and torque the 1/4-20 UNF hex head screws in a star pattern to 160 in-lbs.

1. Hub Assembly (not included)
2. Stainless Steel Insulator (not included)
3. 10034621 Flat Rotor
4. 5/8"-18 UNF Flanged Hex Head Nut (10 ea.)
5. ABS Tone Ring
6. 1/4-20 UNF Hex Cap Screws

See ConMet Service Manual for detailed hub service information.

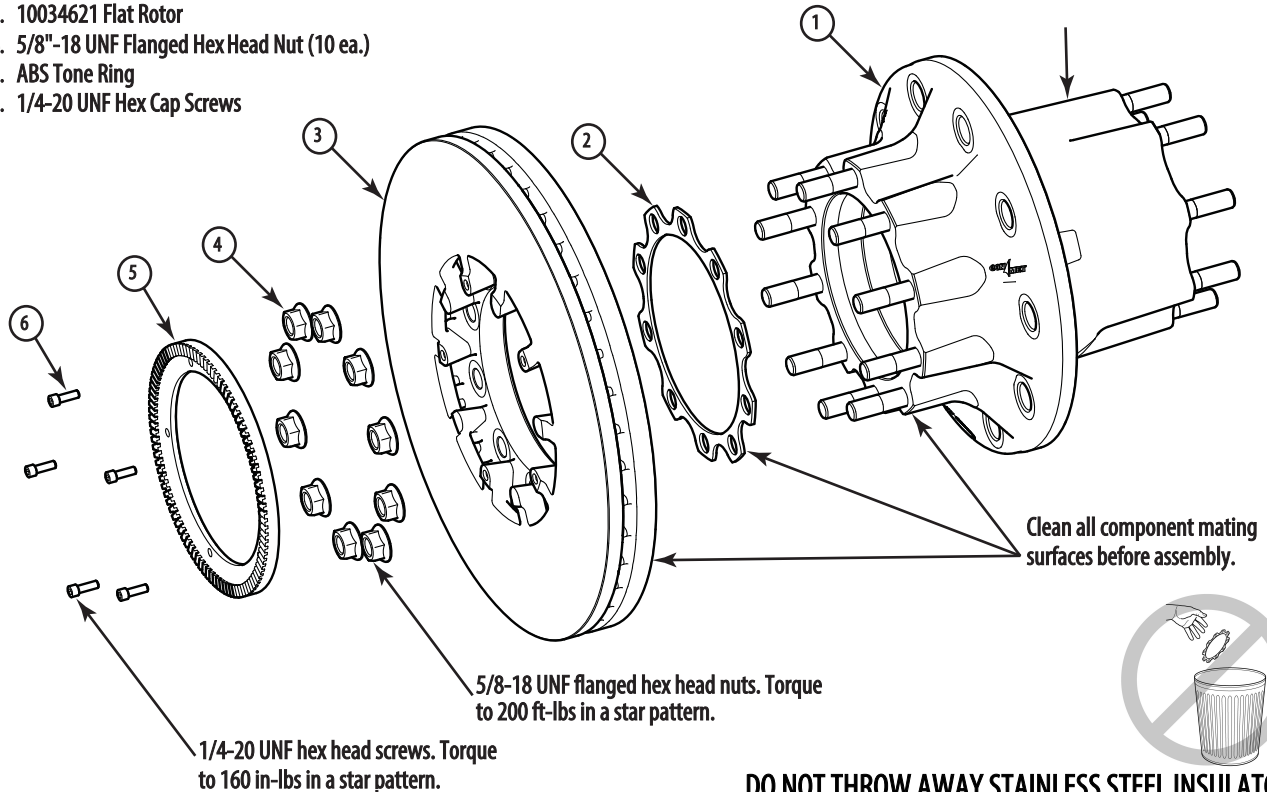

DO NOT THROW AWAY STAINLESS STEEL INSULATOR