



Service Kit Part Number 10041216  
ConMet FF-Front Flat Rotor 10034621  
Rotor Minimum Thickness 1.46" (37 mm)



ConMet 10034621 Flat Rotor

## DISC BRAKE ROTOR REPLACEMENT

### NOTE

Install the brake rotor using only the hardware provided in the kit.

If present, retain stainless steel insulator (see image below).

1. If the rotor mounting studs were removed from the hub during disassembly, apply Loctite® 272 to the coarse end of the double-ended stud and to the rotor mounting threads in the hub. (If Loctite® 272 is not available, use Loctite® 262.) Install and torque the rotor studs to 65 ft-lbs. for iron hubs and 50 ft-lbs. for aluminum hubs.
2. Clean all mating surfaces.
3. Place the stainless steel insulator (for aluminum hubs only) and the rotor on the hub.
4. Install and torque the new, included rotor mounting nuts in a star pattern to 200 ft-lbs.
5. Press the ABS ring onto the hub.

1. Hub Assembly (not included)
2. Stainless Steel Insulator (not included, for aluminum hubs only)
3. 10034621 Flat Rotor
4. 5/8"-18 UNF Flanged Hex Head Nut (10 ea.)
5. ABS Tone Ring

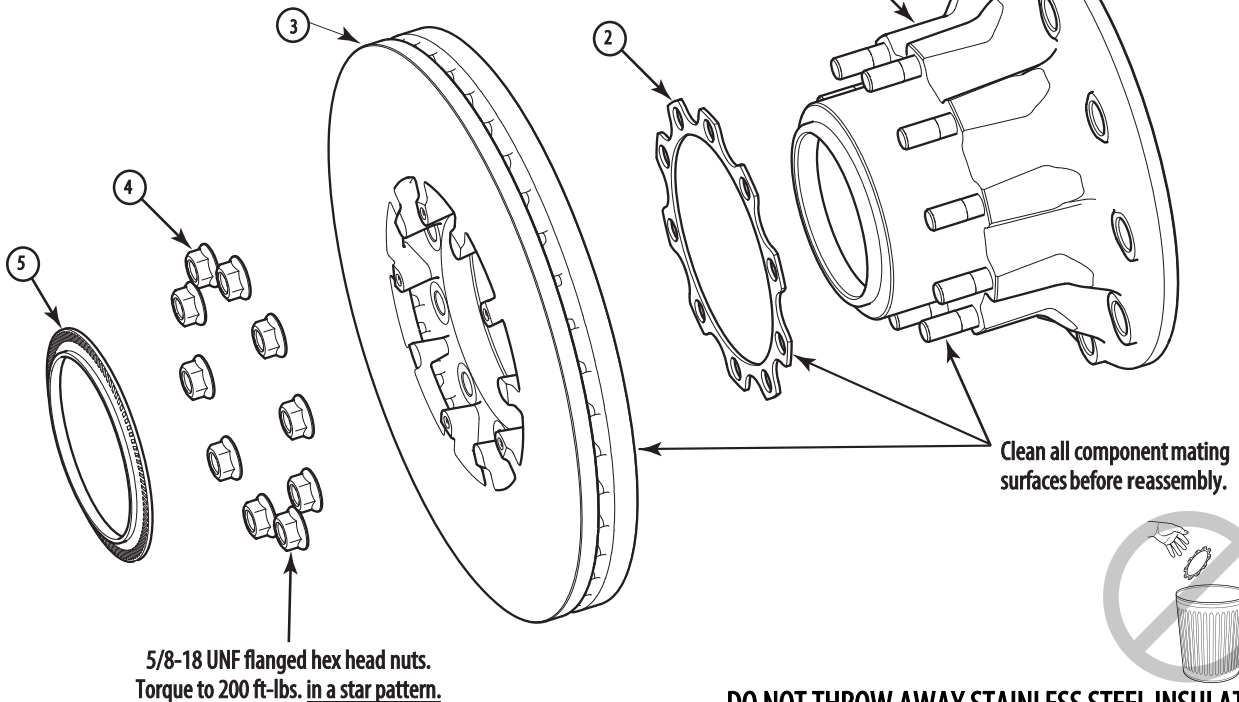

**DO NOT THROW AWAY STAINLESS STEEL INSULATOR**