

VELUX®

Commercial

Sub-construction for Atrium Ridgelight 25-40°

VELUX Modular Skylights

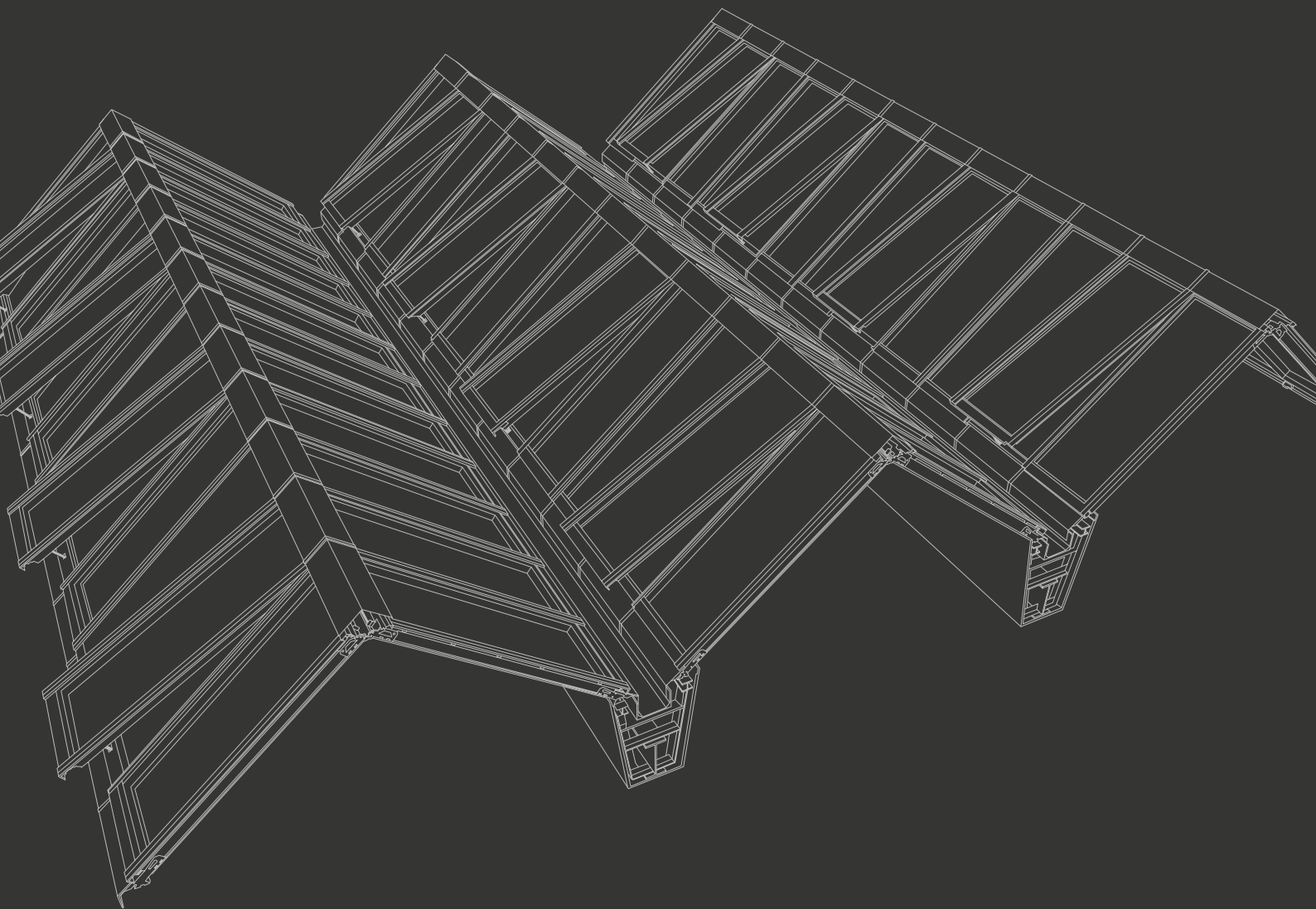

Index

Sub-construction for Atrium Ridgelight 25-40 °	3
Building site measurements – Axonometric	4
Building site measurements	5
Sub-construction variants	6
Securing modular skylights to the sub-construction	8
Using steel profile	8
Straightness of steel profile	8
Using flat steel	9
Straightness of flat steel	9
Using wooden battens	10
Connecting to the roof	11
Static information for dimensioning	12
Sub-construction dimensioning requirements	13

Before you start

Before you can build a durable and secure sub-construction to provide the supporting base of the VELUX Modular Skylights, you will need to have the following three specification documents at hand and follow them closely:



Sub-construction quality assurance (QA) document and specification document. These two documents must be obtained through your local VELUX Commercial sales office.



This is the Sub-construction document for Atrium Ridgelight 25-40°. You are browsing the brochure now.

Sub-construction for Atrium Ridgelight 25-40°

VELUX modular skylights installed in a Atrium Ridgelight solution are build on a sub-construction made of wood, steel or concrete. The sub-construction raises the modules above the roof surface, protecting the construction against water and drifting snow, and provides the supporting base for the modular skylights.

The sub-construction is not included in the VELUX delivery. The sub-construction as shown in the drawing only represents general principles and must be designed and dimensioned to fit the specific building project, local architectural style and practice, and the directions of other building suppliers.

Atrium Ridgelight 25-40° A delivery of VELUX Commercial

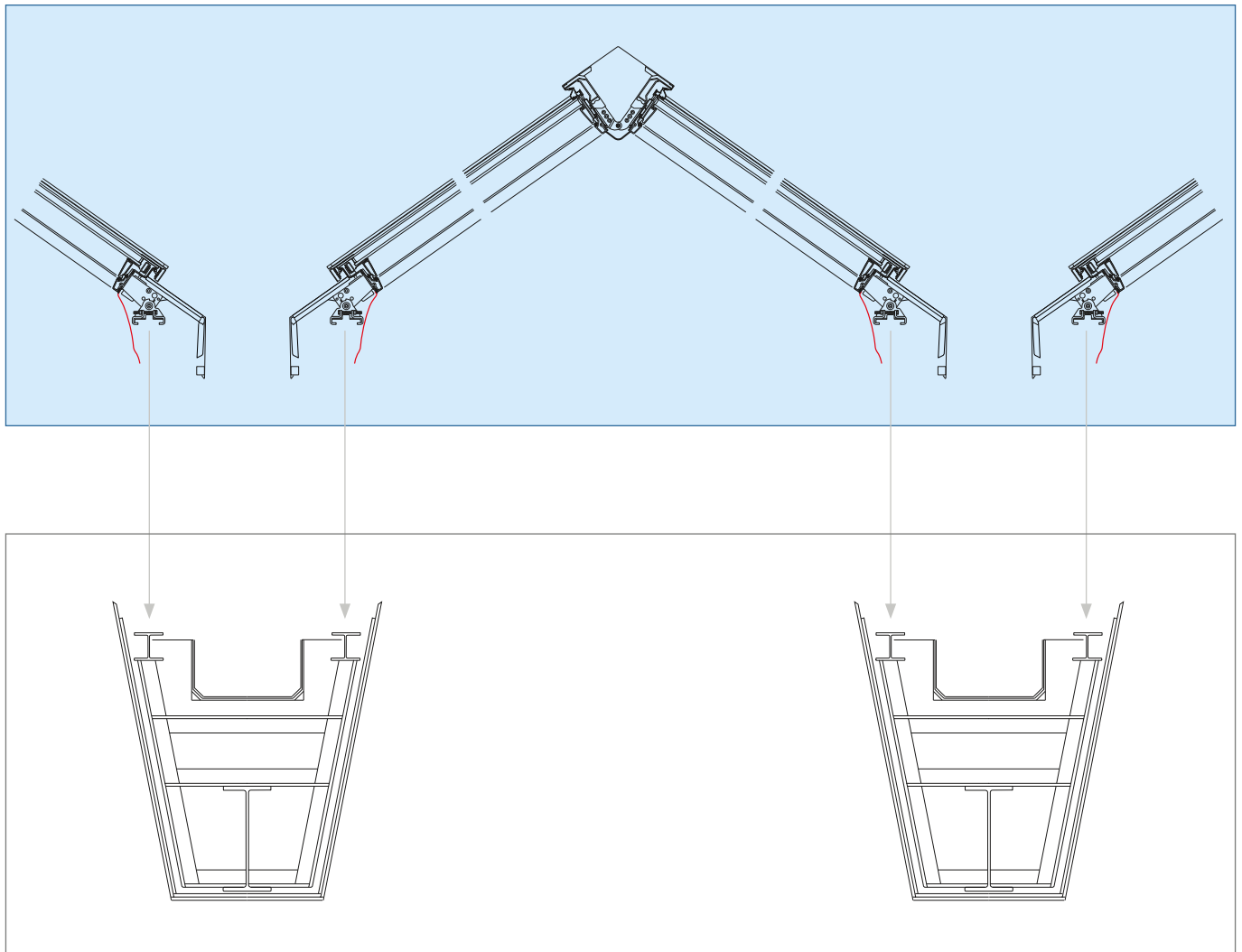

On-site sub-construction This is not delivered by VELUX Commercial

To ensure a high quality installation of VELUX modular skylights and to prevent condensation occurring within the sub-construction, it is highly recommended to install the BCX vapour barrier connection strip. The factory-finished BCX creates the perfect connection between the VELUX modular skylights and the vapour barrier of the building. BCX is CE-marked in accordance with EN 13984.

Building site measurements – Axonometric

Axonometric	
C	Sub-construction width – Tolerance ± 5 mm
D	Sub-construction length – Tolerance ± 5 mm
O	Difference in height of sub-construction – Tolerance ± 5 mm

Minimum length of steel profiles is equal to opening length (B) + 136 mm

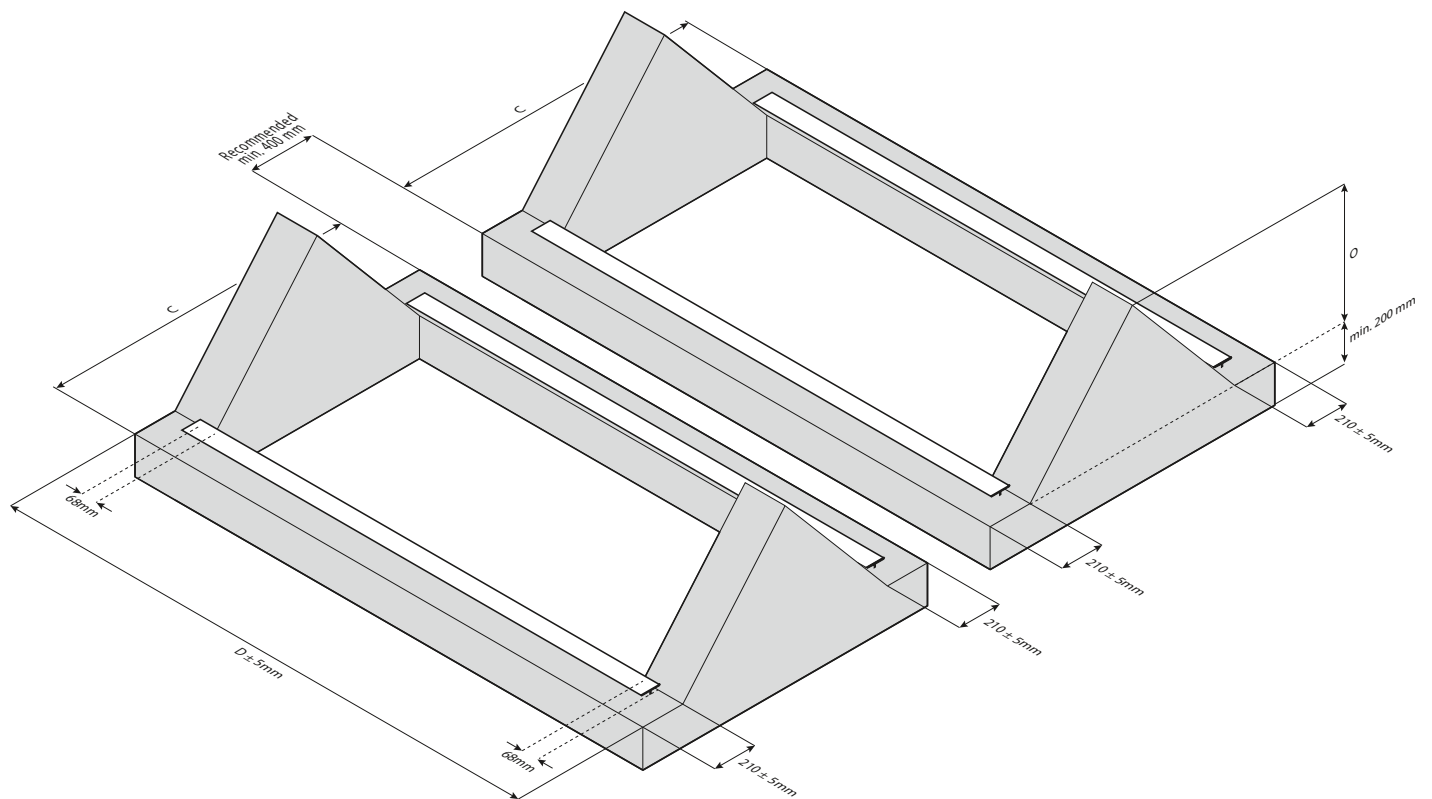

Building site measurements

Plan	
A	Opening width
B	Opening length
C	Sub-construction width – Tolerance ± 5 mm
D	Sub-construction length – Tolerance ± 5 mm
O	Difference in height of sub-construction – Tolerance ± 10 mm
S	Distance between steel, internal measurement between steel – Tolerance ± 10 mm

Minimum length of steel profiles is equal to opening length (B) + 136 mm

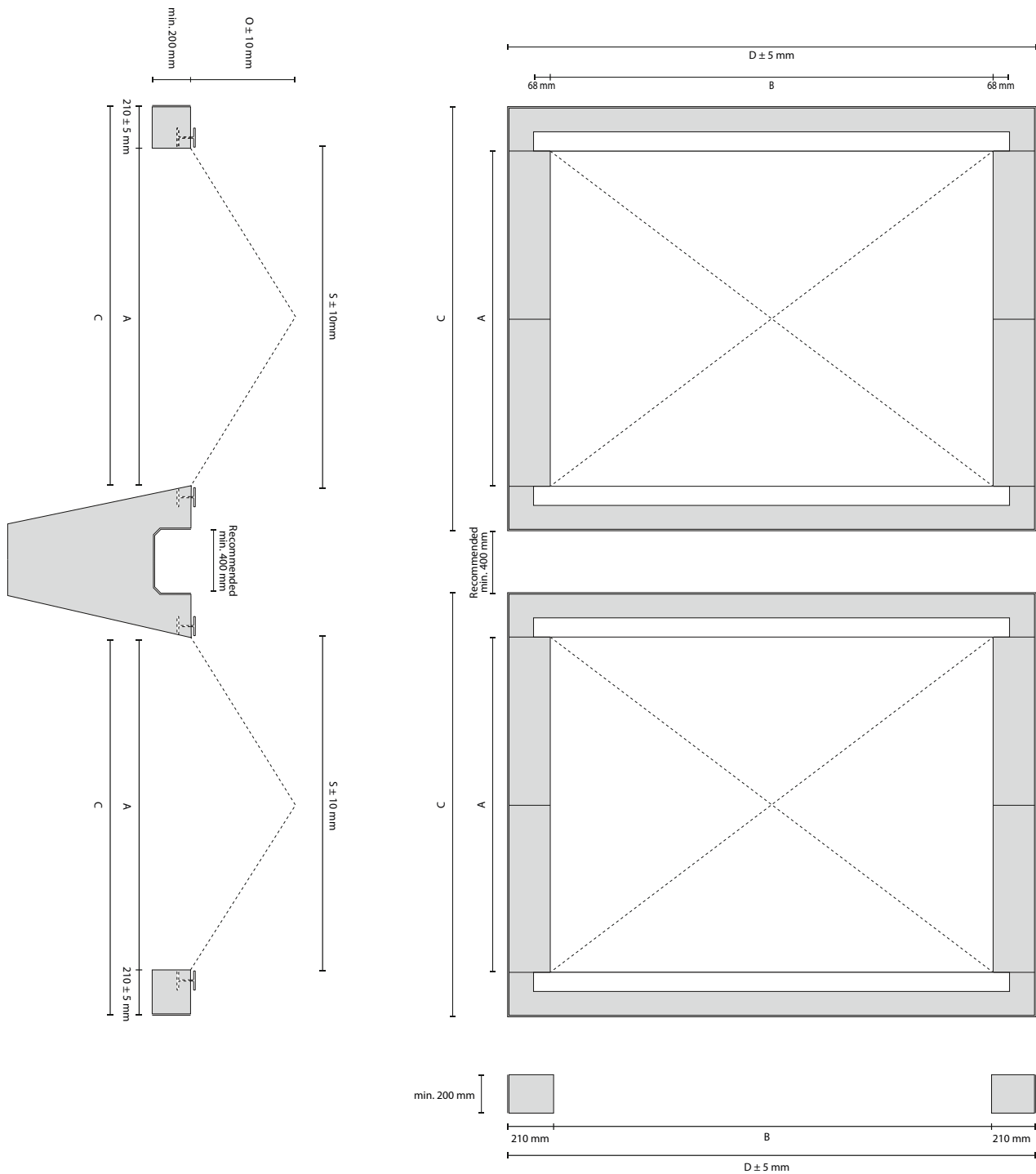

Sub-construction variants

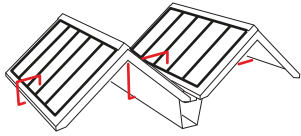

Cross section / Bottom and top

Options of sub-constructions for Atrium Ridgelight at 25-40° solutions. Please note that the width stated indicates the distance from the exterior of the roofing material to the interior edge of the steel profile or wooden batten.

Steel sub-construction

For installation on steel profile

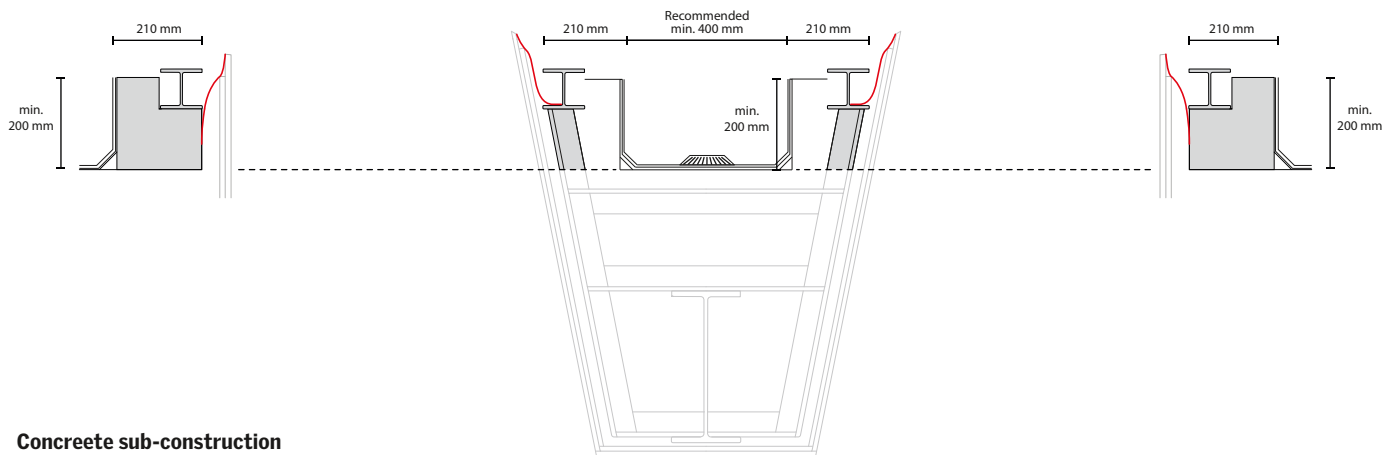

Concrete sub-construction

For installation on flat steel

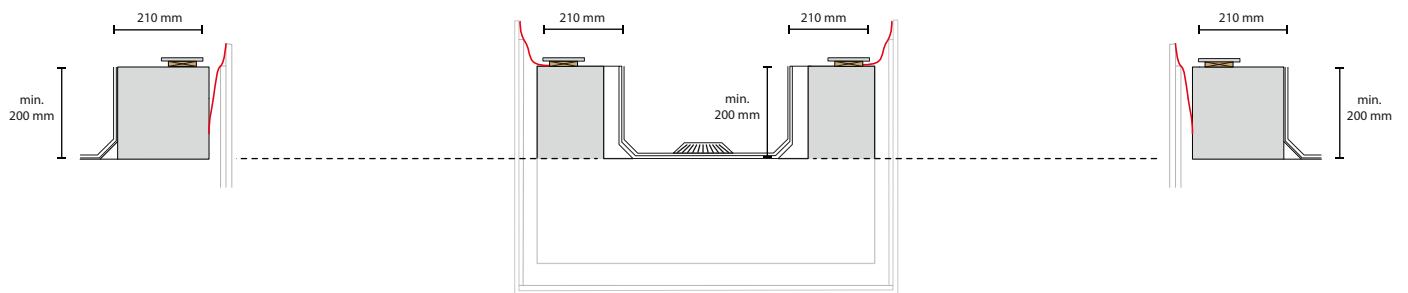

Not recommended by VELUX Commercial

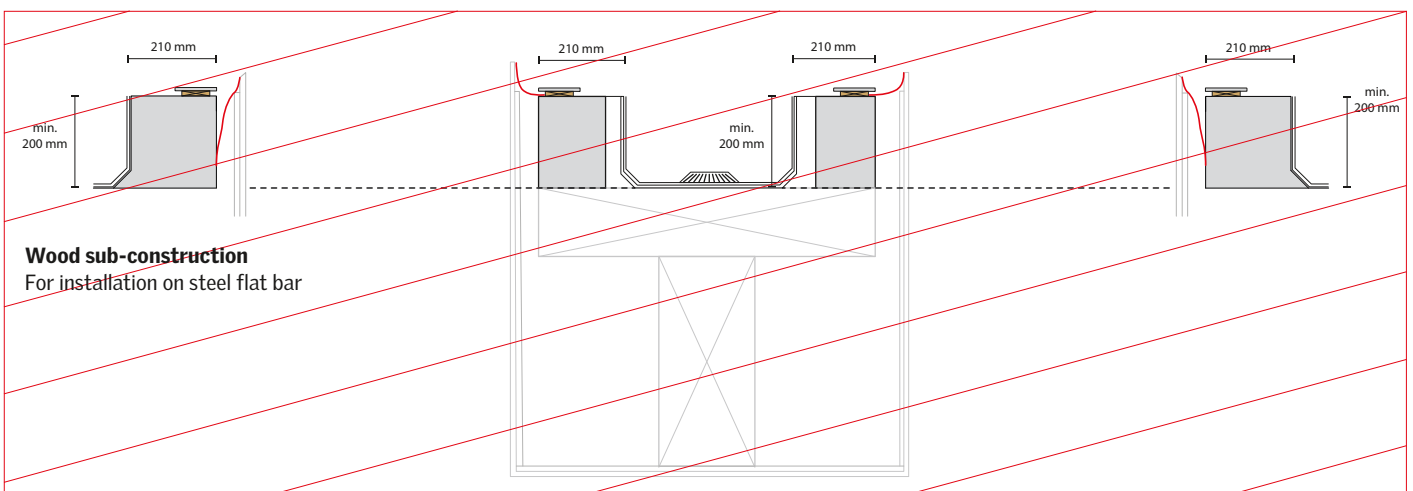

Wood sub-construction

For installation on steel flat bar

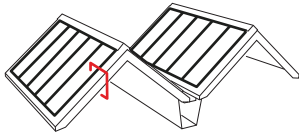

Longitudinal section

In the gable construction for Ridgelight at 25-40° pitch, the height of the sub-construction must be at least 200 mm measured from finished roof surface. It is important that the surface of the gable construction is suitable for fixation of screws.

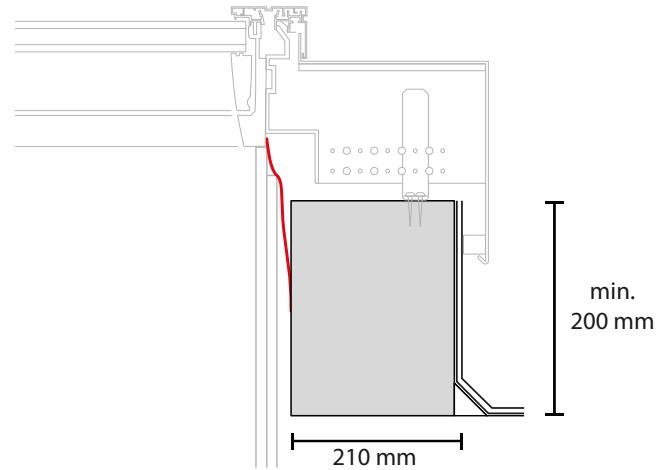

Securing modular skylights to the sub-construction

The sub-construction can be finished at the bottom with steel profile, which provides a level and stable surface for the skylight modules and forms a base for fitting mounting brackets with clamps.

Using steel profile

When mounting the modular skylight on a steel profile, the top flange of the profile must be 100 mm in width and 8-11 mm in thickness. In addition there must be at least 15 mm free space underneath the flange both vertically and horizontally to give room for the clamp.

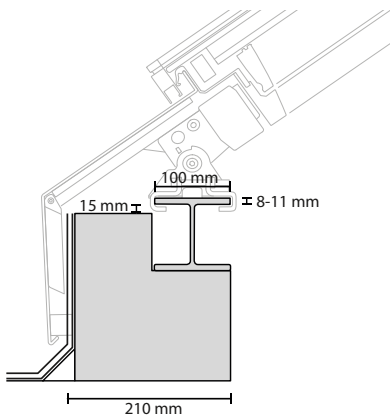

Steel, concrete or wood construction with steel profile

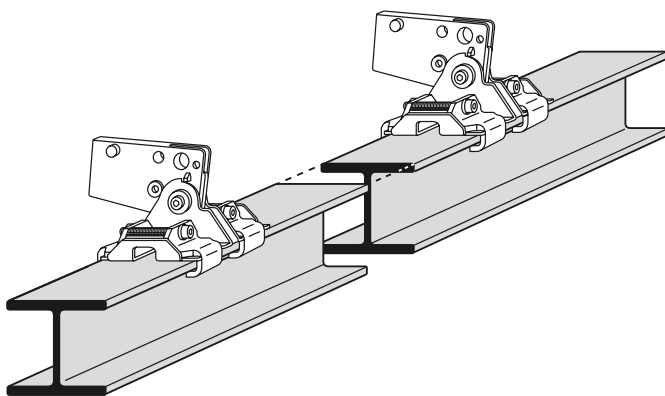

Connestion of steel profiles must not collide with clamps

The number and size of fixings for securing the steel profile to the sub-construction must be dimensioned by the customer to fit each project.

Straightness of steel profile

Requirements as to the straightness of the steel profile are 2 mm per 2 meters both horizontally and vertically.

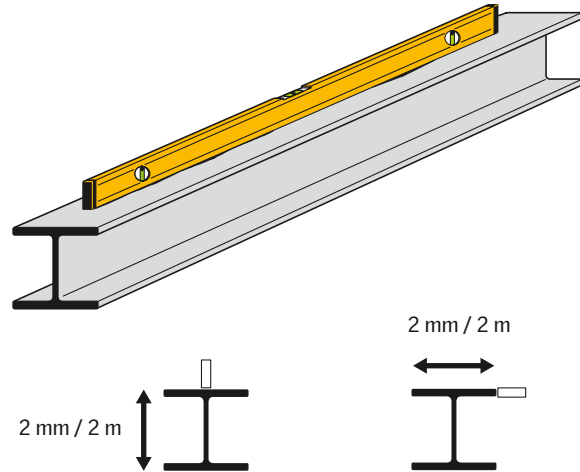

The following standard steel profiles are suited for installation of VELUX modular skylights in Ridgelight solutions.

EU steel beams	British steel beams	US steel beams
INP 220	UB 178 x 102 x 19	W 12 x 22
IPE 200	UB 203 x 102 x 23	W 12 x 19
HE100A	UB 254 x 102 x 22	W 10 x 19
HE100B	UB 254 x 102 x 25	W 10 x 17
	UB 305 x 102 x 25	W 8 x 15
	UB 305 x 102 x 28	W 6 x 16
	UB 305 x 102 x 33	W 4 x 13
		S 8 x 23
		S 8 x 18.4

In case a stronger construction is needed, the steel profile can be replaced with a stronger profile. In this case, longer installation bolts must be ordered separately from a VELUX Commercial sales office.

The following profiles can be combined with the longer bolts.

EU steel beams	US steel beams
INP 240, 260, 280	S 10 x 25.4
IPE 220, 240	
HE120A	
HE120B	

Using flat steel profile

When the sub-construction is finished with a flat steel profile, the steel profile must be 100 mm in width and 8-11 mm in height. In addition there must be at least 15 mm free space underneath the steel both vertically and horizontally to give room for the clamps.

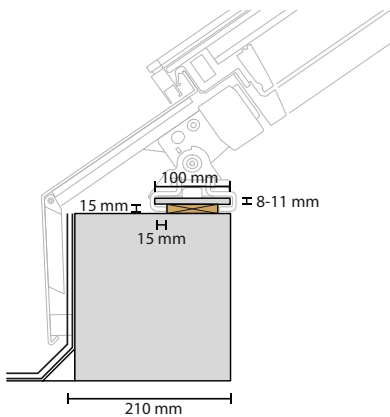

Steel, concrete or wood construction with flat steel

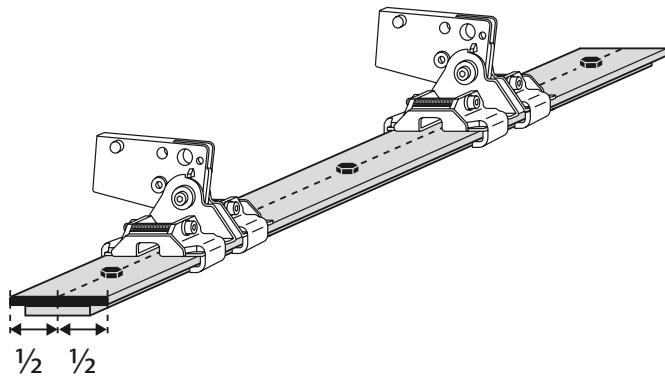

- The distance pieces under the flat steel profile must be for the full length of the steel profile
- The flat steel profile must be secured using screws along the middle of the steel profile

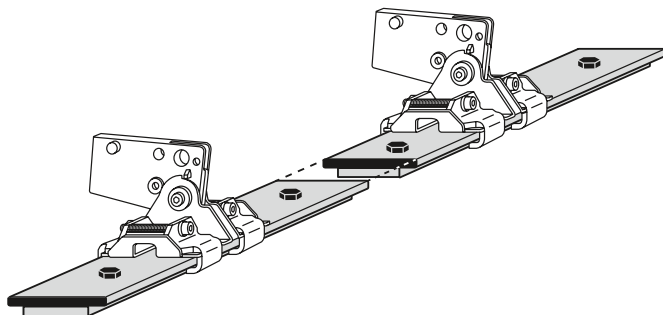

- Connection of flat steel profiles must not collide with clamps

The number and size of fixings for securing the flat steel profile to the sub-construction must be dimensioned by the customer to fit each project.

Straightness of steel profile

Requirements as to the straightness of the flat steel are 2 mm per 2 meters both horizontally and vertically.

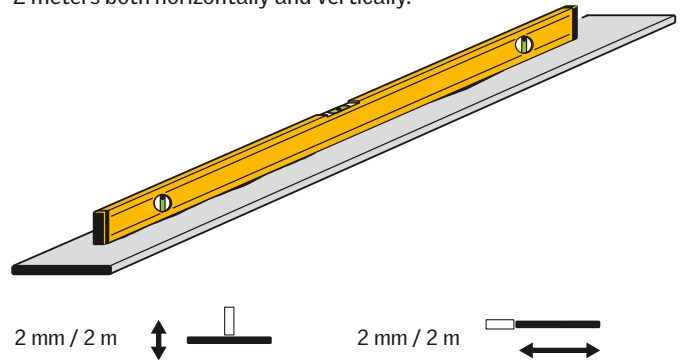

The following standard flat steel profiles are suited for installation of VELUX modular skylights in Ridgelight solutions.

Standard EU flat steel	Standard US flat steel
100 x 8	5/16 x 4
100 x 10	3/8 x 4

In case a stronger construction is needed, the steel profile can be replaced with a stronger profile. In this case, longer installation bolts must be ordered separately from a VELUX Commercial sales office.

The following flat steel profiles can be used combined with the longer bolts.

Standard EU flat steel	Standard US flat steel
110 x 8	3/8 x 4 1/2
110 x 10	
120 x 8	
120 x 10	

Using wooden battens

The sub-construction for the Ridgelight can also be finished with the use of a wooden batten on which the mounting brackets of the modular skylight can be secured directly, without having to use the mounting clamps.

The skylight modules are mounted on the batten using screws through the bottom and top mounting brackets.

There are 4 holes in each mounting bracket, 2 x $\phi 5$ and 2 x $\phi 8.5$.

These screws are not included in the VELUX delivery, and the correct dimensions must be ensured by the customer.

Not recommended by VELUX Commercial

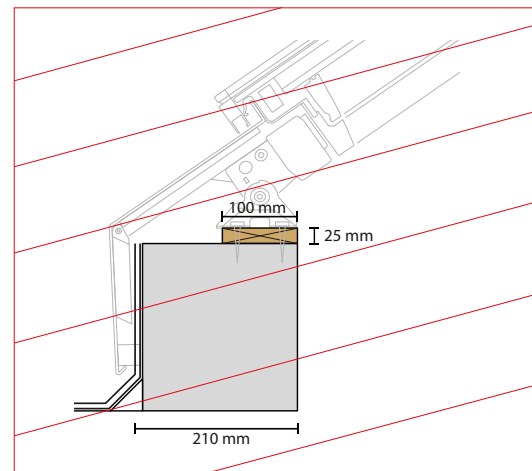

Steel, concrete or wood construction with wooden batten

Connecting to the roof

The surface on which roofing felt is laid must be prepared according to applicable standards for roofing materials and best building practice.

The ideal installation order, is to apply the roofing felt to the outside of the sub-construction before mounting the skylights.

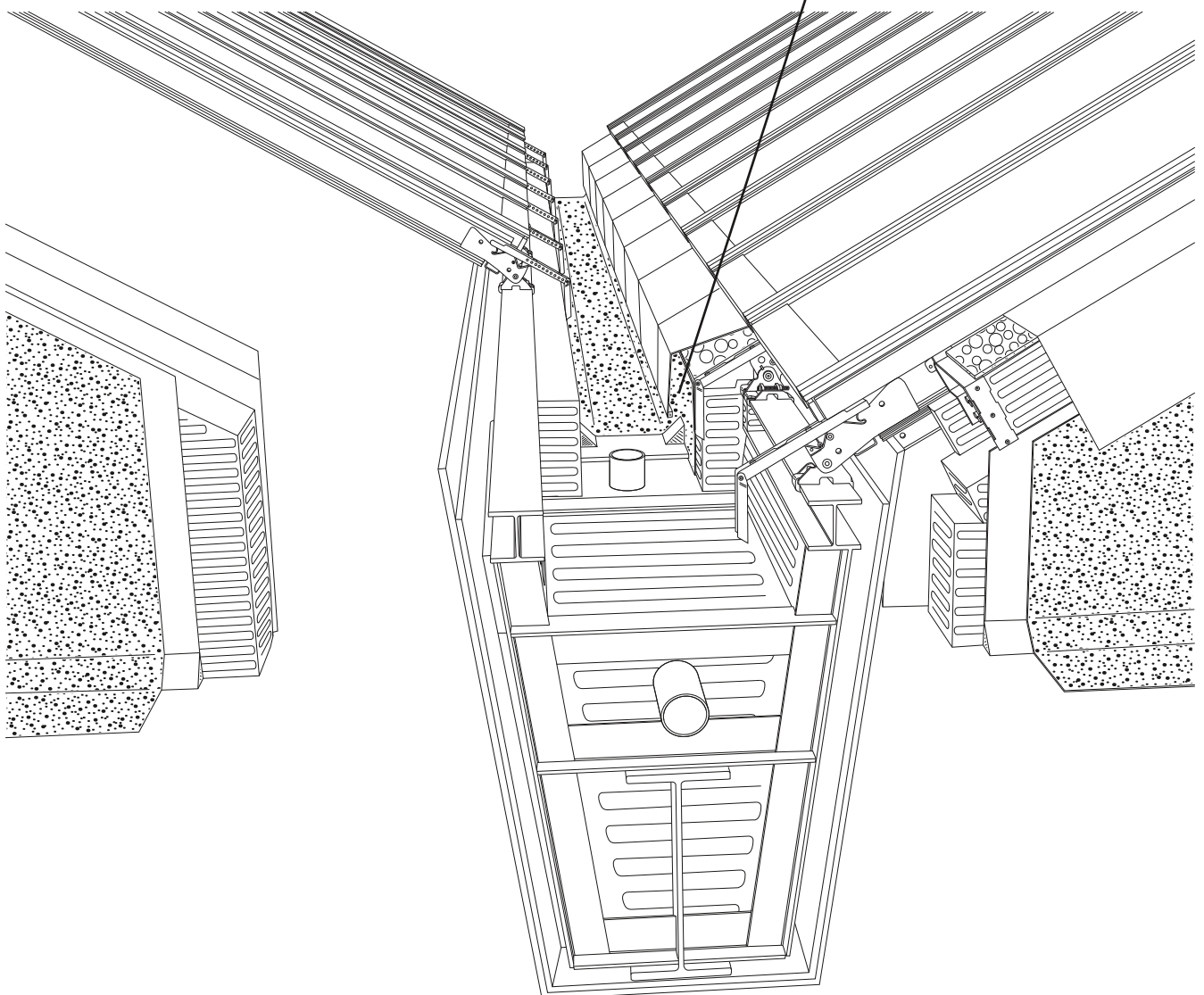
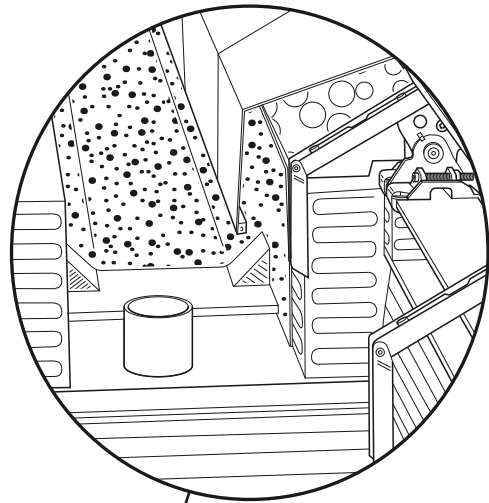

Static information for dimensioning

As an additional service VELUX Commercial offers to provide static calculation for the skylight solution, based on the actual loads given

by the customer. For static calculation please contact VELUX Commercial sales office.

Static model of reactions

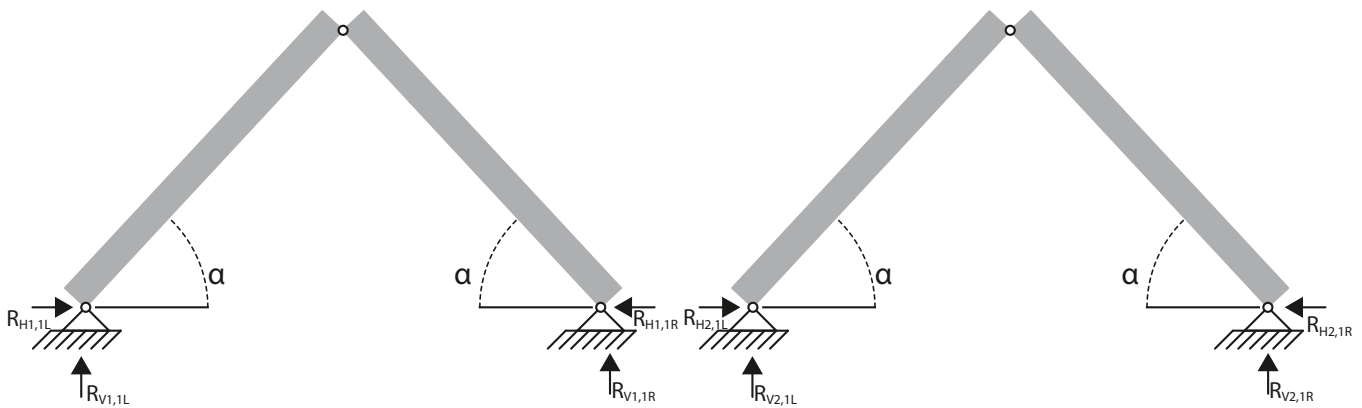

Characteristic loads

Fill out please

Name of your project:

Snowload pressure in kN/m²

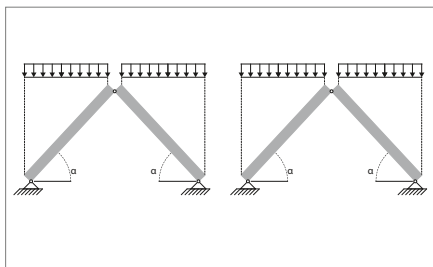

Windload pressure in kN/m²

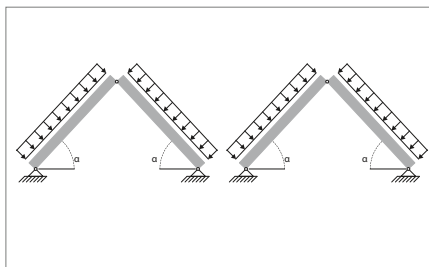

Windload suction in kN/m²

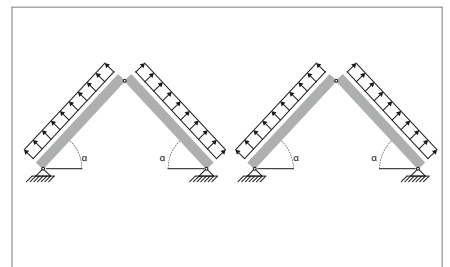

Sub-construction dimensioning requirements

The roof construction is subject to deflection after installation of the skylight modules. These deflections includes subsequent roof covering, various building installations and external loads such as snow and wind etc. The sub-construction must be designed to withstand all these loads and the deformations must be limited to $1/400$ over the full length of the sub-construction.

After completing the sub-construction, it must be secured against water penetrating the roof construction and insulation.

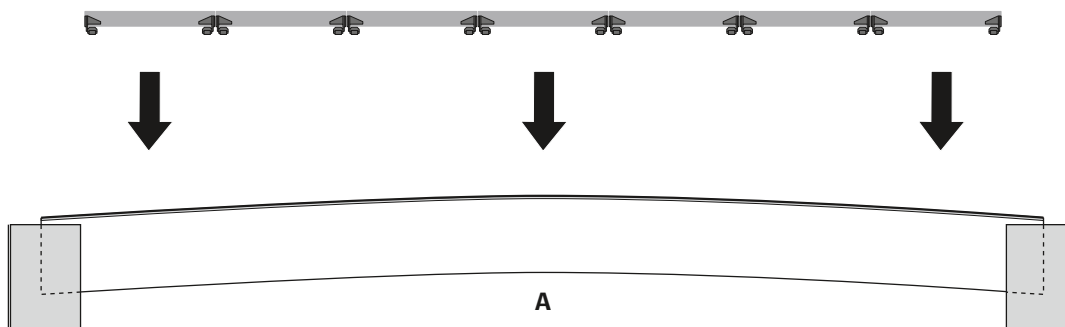
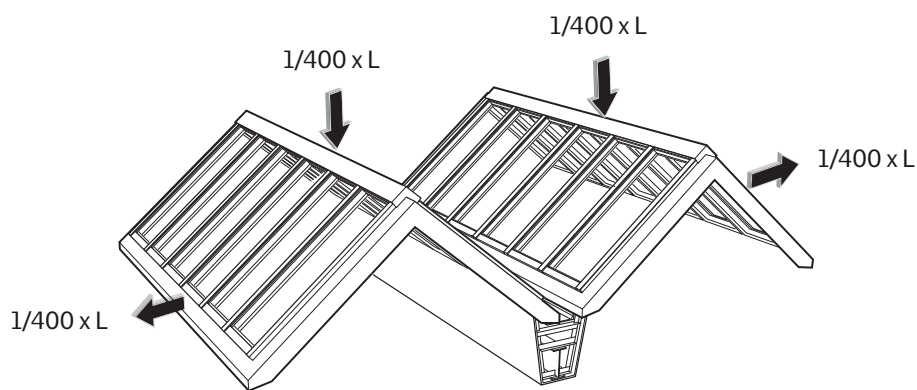

A: Beams can be constructed with a camber height to withstand the weight from the modules

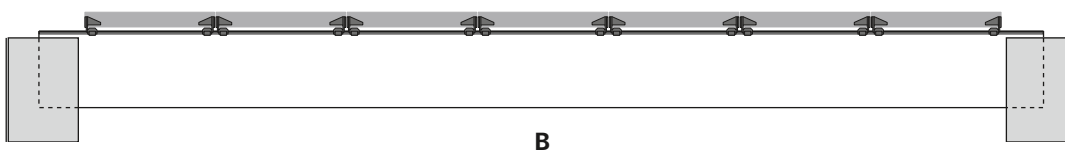

B: After the installation the beams are flat level

VELUX Group
VELUX Commercial
Ådalsvej 99
2970 Hørsholm
Denmark

Email: vms@velux.com
Web: veluxcommercial.com
Blog: commercial.velux.com/blog

Bringing light to life™

VELUX®

Commercial