

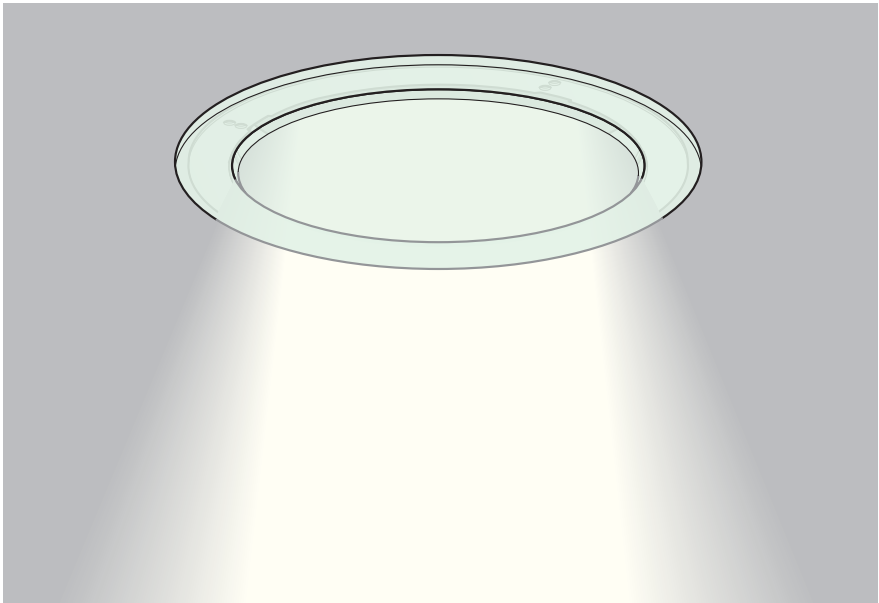

ZTZ 213

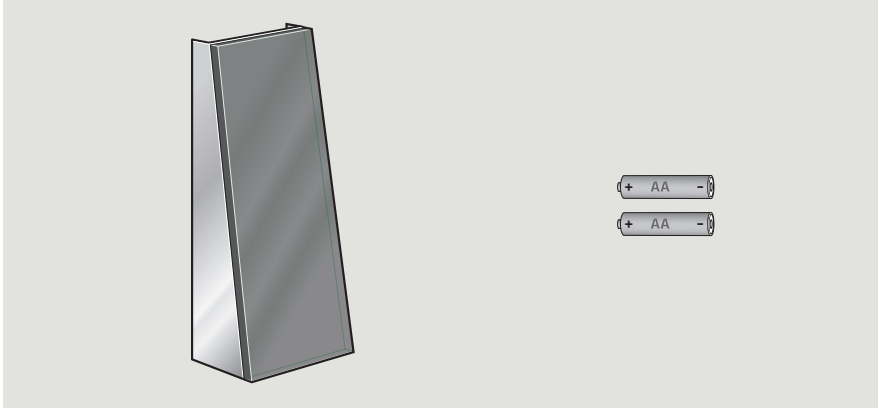

INSTALLATION INSTRUCTIONS FOR ZTZ 213 ©2018, 2021 VELUX GROUP @VELUX AND THE VELUX LOGO ARE REGISTERED TRADEMARKS USED UNDER LICENSE BY THE VELUX GROUP
INSTRUCTIONS D'INSTALLATION POUR ZTZ 213 ©2018, 2021 VELUX GROUP @VELUX ET LE LOGO VELUX SONT DES MARQUES DE COMMERCE DÉPOSÉES ET EMPLOYÉES SOUS LICENCE DE VELUX GROUP

AU: VELUX Australia Pty. Ltd.
1300 859 856
www.velux.com.au

CA: VELUX Canada Inc.
1 800 88-VELUX (888-3589)
www.velux.ca

JP: VELUX-Japan Ltd.
0570-00-8141
www.velux.co.jp

KR: VELUX International (VELUX A/S)
+45 7632 9240
www.velux.co.kr

NZ: VELUX New Zealand Ltd.
0800 650 445
www.velux.co.nz

US: VELUX America LLC
1-800-88-VELUX
www.veluxusa.com

www.velux.com



VAS 454348-2021-02

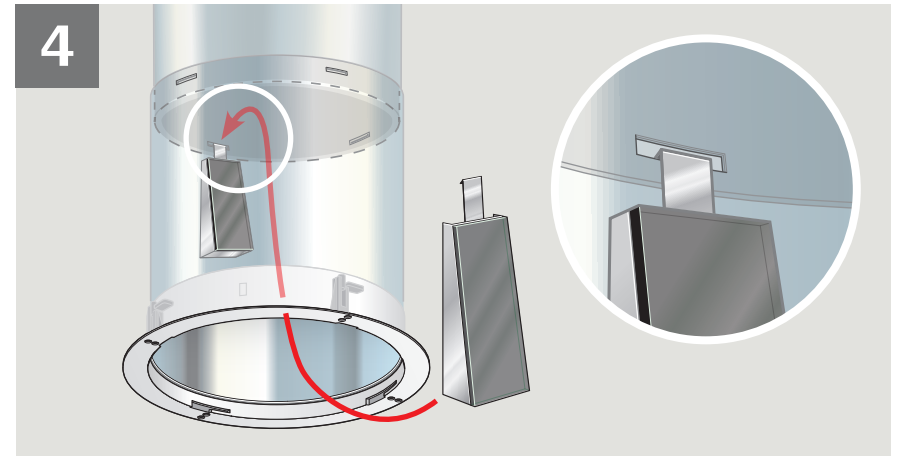
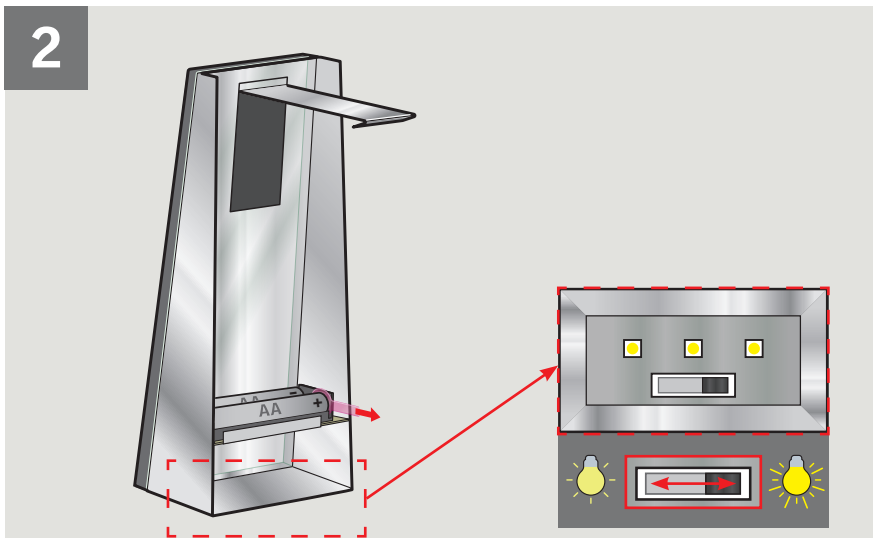
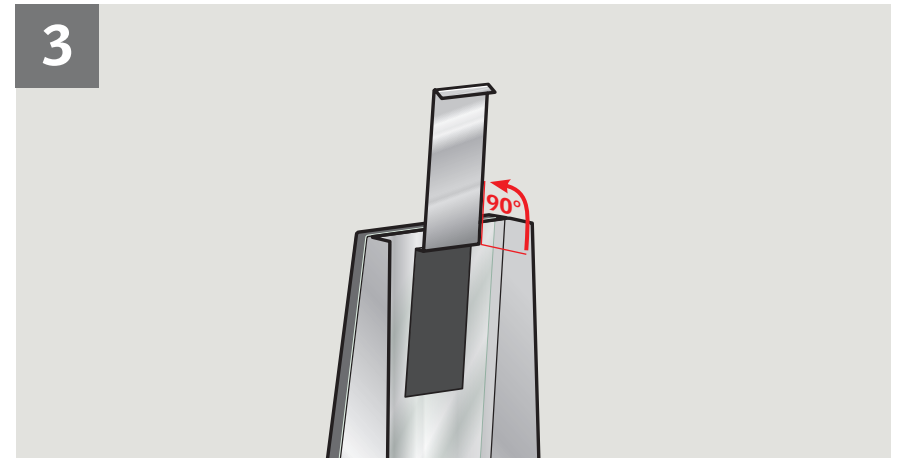
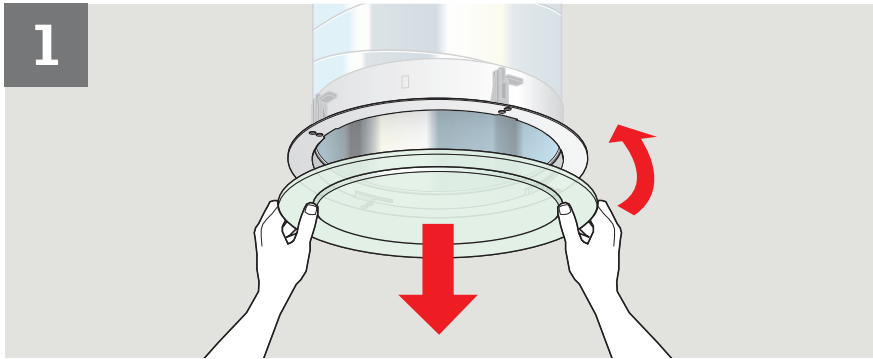

ENGLISH:

⚠ Caution when handling - product may have sharp edges!
Use only rechargeable batteries (NiMH AA, 1.2 V, min. 1800 mAh).
Recycle and dispose of batteries in accordance with local and national regulations.

ESPAÑOL:

⚠ Tenga cuidado al manipular el producto; ¡puede tener bordes filosos!
Use únicamente baterías recargables (NiMH AA, 1.2 V, min. 1800 mAh).
Recicle y deseche las baterías según las normativas locales y nacionales.

FRANÇAIS :

⚠ Attention lors de la manipulation - le produit peut avoir des bords tranchants !
Utilisez uniquement des piles rechargeables (NiMH AA, 1,2 V, min. 1800 mAh).
Recyclez et éliminez les piles conformément aux règlements locaux et nationaux.

