

THE POWER OF

REDARC®

BCDC1212S

**12 A DC-DC / 40 A SOLAR 3-STAGE
IN-CABIN 12 V BATTERY CHARGER**

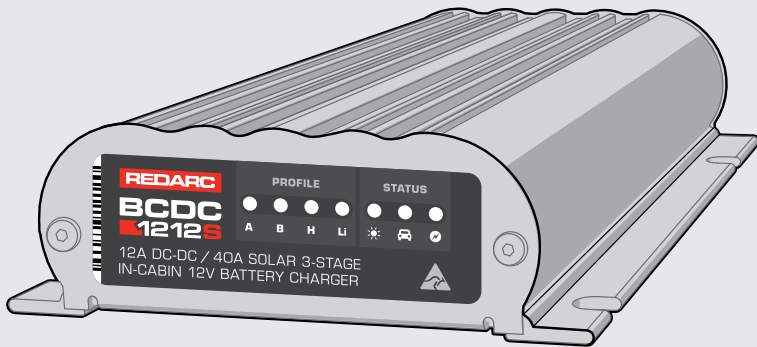

CONTENTS

WARNINGS AND SAFETY INSTRUCTIONS	3
PRODUCT OVERVIEW	4
Cables and Wires	5
Profile LEDs	6
Status LEDs	6
PRODUCT FUNCTION	7
BASIC SETUP	9
SYSTEM PLANNING	10
What You Will Need	10
Cable sizing	11
Fuse Requirements	11
Considerations Prior to Installation	12
INSTALLATION – MOUNTING	14
Mounting Requirements	14
Mounting Instructions	15
INSTALLATION – WIRING	16
Cable Assembly	16
Lug Assembly	17
Solar Connectors	17
Cable Connections	18
Maintenance	24
TROUBLESHOOTING	25
Error Codes	26
Turn On/Off Thresholds	27
FREQUENTLY ASKED QUESTIONS	28
SPECIFICATIONS	29
WARRANTY	31



For the latest version of this document and any available translations, visit the product page on the REDARC website at www.redarcelectronics.com

WARNINGS AND SAFETY INSTRUCTIONS

SAVE THESE INSTRUCTIONS – This manual contains important safety instructions. Do not operate the system unless you have read and understood this manual. REDARC recommends that the BCDC1212S referenced in this manual be installed by a suitably qualified person.

Disclaimer: REDARC accepts no liability for any injury, loss or property damage which may occur from the improper or unsafe installation or use of its products.

SAFETY MESSAGE CONVENTIONS

Safety messages in this manual include a signal word to indicate the level of the hazard as follows:

⚠ WARNING: Indicates a potentially hazardous situation which could result in death or serious injury to the operator or to bystanders.

⚠ CAUTION: Indicates a potentially hazardous situation which may result in moderate or minor injury to the operator or to bystanders.

NOTICE: Indicates a situation that may cause equipment damage.

⚠ WARNING

RISK OF EXPLOSIVE GASES: Working in vicinity of a Lead-Acid battery is dangerous. Batteries generate explosive gases during normal operation. For this reason, it is of utmost importance that you follow the instructions when installing and using the Charger.

⚠ CAUTION

1. The BCDC1212S should not be used by persons (including children) with reduced physical, sensory or mental capabilities, or lack of experience and knowledge, unless they are supervised or have been instructed on how to use the appliance by a person responsible for their safety. Children should be supervised to ensure that they do not play with the Battery Charger.
2. Do NOT alter or disassemble the BCDC1212S under any circumstances. All faulty Units must be returned to REDARC for repair. Incorrect handling or reassembly may result in a risk of electric shock or fire and may void the Unit warranty.
3. Only use the Battery Charger for charging Standard Automotive Lead Acid, Calcium Content, Gel, AGM, SLI, Deep Cycle, Heated Lithium or Lithium Iron Phosphate type 12V batteries.
4. When using the BCDC1212S to charge a Lithium Iron Phosphate battery, only batteries that have an inbuilt battery management system featuring under and over voltage protection and cell balancing are suitable.

5. The Heated Lithium (H) charging profile should only be used with lithium batteries that feature a functioning heating element. If unsure, the standard Lithium (Li) charging profile must be used. Using the wrong charging profile may damage your lithium battery.
6. Check the manufacturer's data for your battery and ensure that the 'Maximum' voltage of the profile you select does not exceed the manufacturer's recommended maximum charging voltage. If the 'Maximum' voltage is too high for your battery type, please select another charging profile.
7. Check the manufacturer's data for your battery and ensure that the 'Continuous Current Rating' of the Charger does not exceed the manufacturer's recommended maximum charging current.
8. The BCDC1212S is not intended to supply power to a low voltage electrical system other than to charge a battery.
9. Cable and fuse sizes are specified by various codes and standards which depend on the type of vehicle the BCDC1212S is installed into. Selecting the wrong cable or fuse size could result in harm to the installer or user and/or damage to the BCDC1212S or other equipment installed in the system. The installer is responsible for ensuring that the correct cable and fuse sizes are used when installing this Battery Charger.
10. NEVER smoke or allow a spark or flame in vicinity of battery or engine. This may cause the battery to explode.

PERSONAL SAFETY PRECAUTIONS

To assist with the safe operation and use of the BCDC1212S when connected to the battery:

- a. Wear complete eye protection and clothing protection. Avoid touching eyes while working near a battery.
- b. If battery acid contacts your skin or clothing, remove the affected clothing and wash the affected area of your skin immediately with soap and water. If battery acid enters your eye, immediately flood the eye with running cold water for at least 10 minutes and seek medical assistance immediately.



PRODUCT OVERVIEW

The BCDC1212S Battery Charger is specifically designed for, but not limited to, applications where the input current required to charge a trailer mounted auxiliary battery is drawn through the vehicle's towing harnesses and connectors. The Battery Charger is capable of drawing 40A from 12V solar panel/s and limits vehicle input current to 12 A from 12V vehicle alternators, keeping your auxiliary battery system fully charged.

Designed around REDARCs tried and tested charging technology, the BCDC1212S features a DC-DC charger, an MPPT solar regulator and a smart battery isolator all packed into one compact, lightweight unit. Using this proven combination, the BCDC1212S fully charges common types of 12V automotive AGM/Gel, Standard Lead Acid, Calcium or LiFePO₄ lithium batteries while protecting your vehicles start battery from excessive discharge.

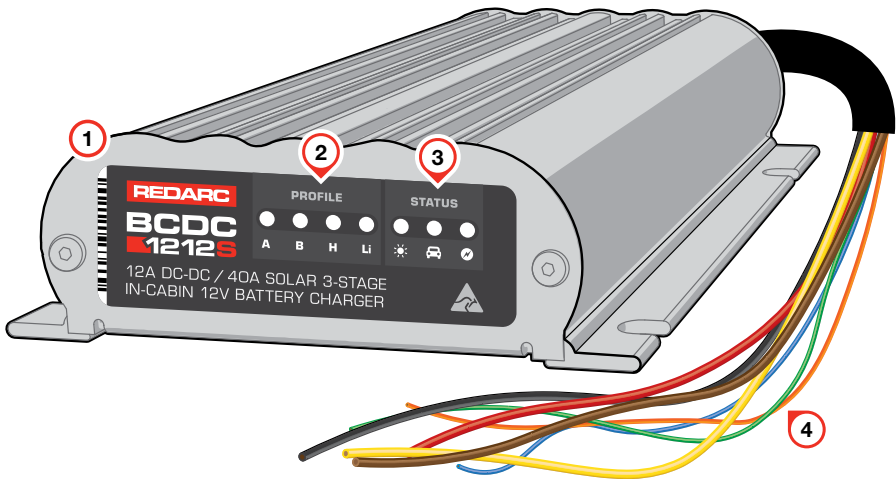

1. BCDC1212S Battery Charger

2. Profile LEDs

Displays the charge profile of the BCDC (page 6).

3. Status LEDs







Displays the charge status of the BCDC (page 6).

4. Cables and Wires

See page 5 for wiring information.

CABLES AND WIRES

The BCDC1212S Battery Charger is equipped with a fly lead wiring harness that must be correctly connected to ensure effective charging of the auxiliary battery. Below is a description of each cable and wire attached to the Unit.

Table 1: Cable and Wire Description				
Wire Colour	Description	Length	Gauge	Purpose
 Brown	Output Cable	392 mm / 15.4"	8 mm ² / 8AWG	Connects to the auxiliary battery positive(+) terminal.
 Black	Ground Cable	424 mm / 16.7"	8 mm ² / 8AWG	Connects to the common ground.
 Orange	Profile Selection Wire	447 mm / 17.6"	0.5 mm ² / 20AWG	Used to configure the Charge Profile.
 Red	Vehicle Input Cable	457 mm / 18"	8 mm ² / 8AWG	Connects to a protected trailer plug or the start battery positive(+) terminal.
 Blue	Vehicle Ignition Wire	479 mm / 18.9"	0.5 mm ² / 20AWG	Connects to ignition signal for vehicles with Smart Alternators.
 Yellow	Solar Input Cable	507 mm / 20"	8 mm ² / 8AWG	Connects to the solar panel input positive.
 Green	External LED Wire	484 mm / 19"	0.5 mm ² / 20AWG	Used to power optional LED / connects to Orange Wire for Standard Lithium batteries.

PROFILE LEDS

The BCDC1212S supports AGM/Gel, Standard Lead Acid, Calcium, and Lithium profiled batteries.

NOTE: Refer to the charging specifications stated by the battery manufacturer, and the installation temperature chart before selecting the profile for your installation.

The selected Profile LED will be on solid when the Unit is ON and charging. A flashing profile LED indicates that the Unit is in standby mode and ready to charge when the vehicle is turned on.

Profile LED

- A. AGM/Gel
- B. Lead Acid/Calcium
- H. Heated Lithium
- Li. Lithium

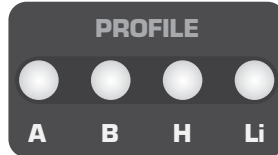

STATUS LEDS

SOLAR & VEHICLE LEDS

The Charge Status LEDs will be on when the input is available and in use. The BCDC1212S will always choose solar before the vehicle input.

CHARGE STAGE LED

The Charge Stage LED indicates the Charge Profile Stage. With any profile selected the Charger will output a 3-Stage charging profile with Boost, Absorption and Float Stages.

Table 2 outlines the LED sequences which indicate these stages and page 7 explains the Charging Process.

Table 2: Charge Stage LED Sequences		
LED Flash Sequence		Profile Stage
Off		OFF / No Output
Continuous		Boost (Constant Current)
2 Seconds		Absorption (Constant Voltage)
2 Seconds		Float

PRODUCT FUNCTION

CHARGING STAGES

BOOST

When the Battery Charger is correctly installed and has a valid power input source it will begin charging the auxiliary battery in the Boost stage. The Boost stage maintains a constant current until the battery voltage reaches its Absorption Voltage. The current in Boost stage may vary during operation in order to maintain safe operating temperature, or to limit the difference between input and output voltages.

ABSORPTION

The Battery Charger will then move to Absorption stage which maintains a constant voltage level for a preset period of time or until the current being drawn by the output battery drops to a predetermined level for 30 seconds; after which the Charger will enter Float stage.

FLOAT

Float stage maintains 13.3V (13.6V for LiFePO₄) on the output battery, keeping the battery topped up. This counteracts the battery's self discharging or loads applied to the battery. When the battery loses charge, the Battery Charger will move back into the Boost stage.

Figure 1: Charging Stages

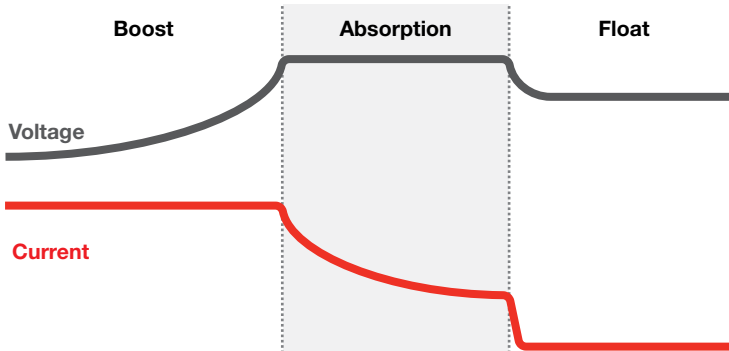

The BCDC has automatic timeouts to protect the battery from being damaged by overcharging. The BCDC will automatically move from Boost to Absorption or Float according to these timeouts. If a timeout occurs before the battery is fully charged, the charge process will begin again from the Boost stage after a brief 'rest-period'. The LiFePO₄ battery profiles timeouts have been designed to suit optimal charging for large lithium battery banks.

⚠ CAUTION: When using the BCDC1212S to charge a Lithium Iron Phosphate battery, only batteries that feature an inbuilt battery management system featuring under and over voltage protection and cell balancing are suitable.

BATTERY TEST MODE

The Battery Charger enters a battery test mode every 100 seconds to check that the input being received from either solar or vehicle battery is still valid and that the auxiliary battery is still correctly connected to the output. This feature protects the vehicle start battery from over discharge as well as protecting the vehicle and its wiring in the event of damage to the output connection.

GREEN POWER PRIORITY

Green Power Priority is an automatic function that defines the order that input sources are prioritised. This ensures that your battery will always take as much power as possible from solar panels before supplementing from other sources. This lightens the load on your vehicle alternator and maximises the energy of free solar.

Charging source priority is given in the following order:

1. Solar (unregulated, 12V solar panel)
2. Alternator (via the Start Battery while the vehicle is running)

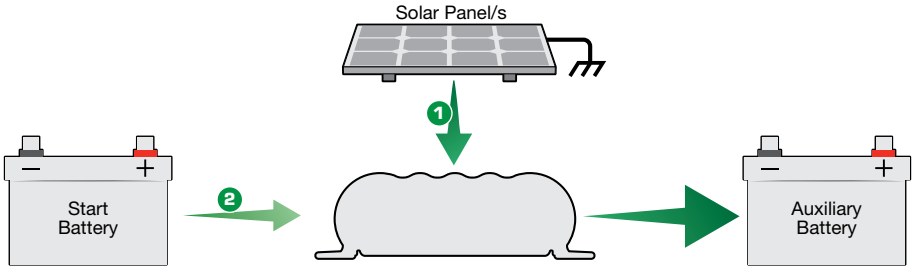

BASIC SETUP

The BCDC1212S must be installed in the following order:

1. Mounting the Unit.
2. **Brown** — Auxiliary battery cable connection
3. **Black** — Ground cable connection
4. **Orange** — Charge profile wire connection
5. **Red and Blue** — Protected trailer plug connection (vehicle ignition wire connection may be required)
6. **Yellow** — Solar cable connection
7. **Green** — Optional LED wire connection

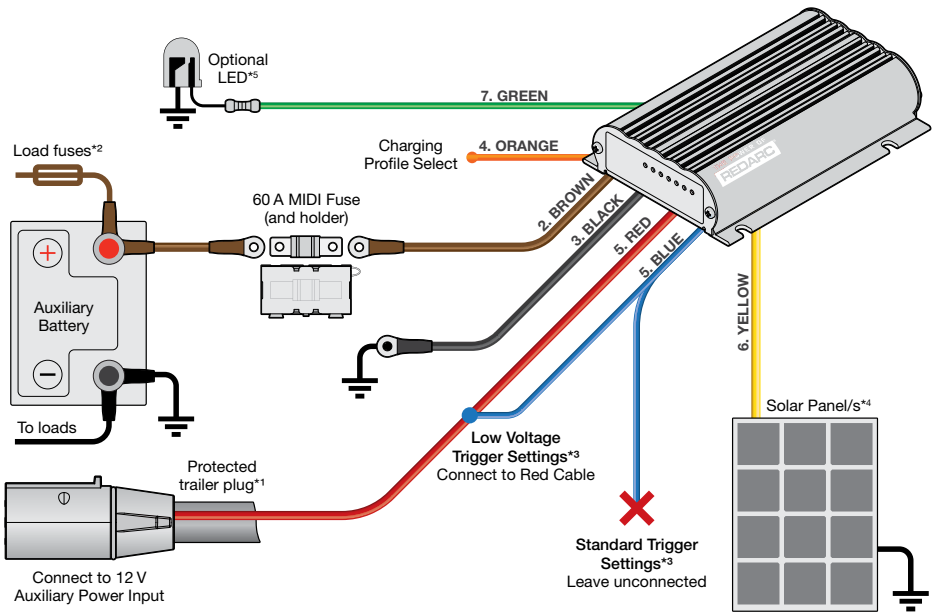

Connect all ground points to chassis earth.

- 1* Connect the **red** (start battery) cable to a trailer plug that is fuse protected, ensuring the fuse size is no greater than 60 A.
- 2* These fuses must be rated slightly higher than the total current draw of all loads connected to the auxiliary battery and is suitably rated for the wiring used. REDARC recommends the use of MIDI type fuses.
- 3* Only use the blue (vehicle ignition) cable if the trailer plug isolates (is not powered) when the vehicle is not running. Using the blue cable with a permanently powered trailer plug may cause the start battery to flatten.
- 4* Do not connect regulated solar panels, the BCDC1212S has an inbuilt regulator.
- 5* If using an Optional LED, use a standard 12V LED with an integrated resistor (12V = 1kΩ or 24V = 2.2kΩ). A basic 3V LED will not operate correctly if installed.

SYSTEM PLANNING

⚠ CAUTION:

- Cable and fuse sizes are specified by various codes and standards which depend on the type of vehicle the BCDC1212S is installed into. Selecting the wrong cable or fuse size could result in harm to the installer or user and/or damage to the BCDC1212S or other equipment installed in the system. The installer is responsible for ensuring that the correct cable and fuse sizes are used when installing this Battery Charger.
- Cabling must be installed in protected areas away from heat sources and sharp objects. Cables must not be routed over or through moving parts of the vehicle. Additional protection such as conduit may be required, especially if routing cables through the engine bay.
- In applications where the BCDC1212S draws power through the vehicle's and trailer's towing harnesses and connectors, the harnesses wiring gauge, connectors and fuse current ratings and fuse type should be checked by a suitably qualified person to ensure that it is adequately rated for safe and reliable operation and that the vehicle's fuse is appropriately rated and located to protect the wiring in the event of a fault, including short circuits.

WHAT YOU WILL NEED

TOOLS

The tools listed may be required for mounting and wiring the BCDC1212S:

- Screwdriver set
- Spanner set
- Socket set
- Pliers
- Side cutters
- Cable cutters
- Ratcheting or Hydraulic crimping tool
- Soldering Iron
- Ratchet

CONSUMABLES

Components not included with the BCDC1212S may be required for mounting, wiring connections and cable management, including:

- Cabling
- Cable connectors, lugs and terminals
- Fuses
- Electrical tape
- Heat Shrink
- Cable ties
- Conduit/Split tubing
- Fasteners/P-Clips

CABLE SIZING

Determine a suitable mounting position for the auxiliary battery and Battery Charger before planning out cables and connections, see [page 14](#) for mounting requirements.

The heavy gauge cables on BCDC1212S carry peak currents of up to 55 A. To carry this current effectively, it is important to select the wire gauge required when extending this cables depends on the length of cable run required. Refer to the table below for cable thickness requirements for the following cables:

- **Brown*** — Output Cable
 - **Black** — Ground Cable
- **Red** — Vehicle Input Cable
 - **Yellow** — Solar Input Cable

***NOTE:** The Brown Output cable should be at maximum 1 m (3'3") in length.

Before making any connections run the cables required for your setup and then trim any excess.

Cable Install Length		Cross Sectional Area	Nearest Equivalent B&S, BAE, AWG	Lug Cable Size
1 – 5 m	3'9" – 16'	≥ 13.6mm ²	6	6 B&S/16mm ²
5 – 9 m	16' – 30'	≥ 20.3mm ²	4	4 B&S/25mm ²

FUSE REQUIREMENTS

Fuses are required for the **brown** (output) and **red** (vehicle input) cable connections and should be mounted within 100 mm (3.9") of cable length from the battery positive (+) terminal. Refer to the table below to determine appropriate fuse sizing.

Connection Type	Current Rating	Fuse Rating	Fuse Type	Recommended Fuse Kit
Output	55 A	60 A	MIDI	FK60
Vehicle Input	12 A	23 A/30 A	MIDI	FK23/FK30

REDARC recommends using MIDI style bolt down fuses as they ensure a low resistance connection. When installing MIDI Fuses, ensure that the nuts securing the fuse and cable lug are tightened all the way down to avoid high resistance connections (see [Figure 2](#)).

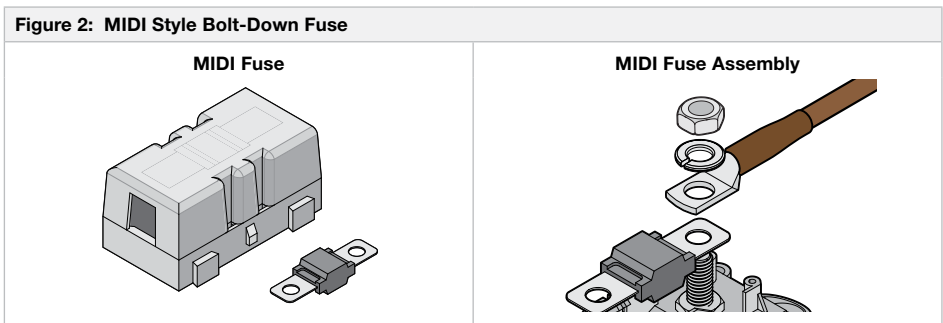

CONSIDERATIONS PRIOR TO INSTALLATION

AUXILIARY BATTERY PROFILE SELECTION

Determine the chemistry of your auxiliary battery prior to install as this will influence the connection of the **orange** cable that is used to set the charge profile (see [page 19](#)).

SOLAR PANEL SELECTION

Consider if your auxiliary battery system will have permanently wired solar panels connected or portable panels such as a solar blanket, this influences wiring and connector choice.

Ensure the panel is 12V nominal and does not have a built in solar regulator.

VEHICLE IGNITION CONNECTION

Confirm the type of alternator your vehicle has to determine if the **blue** (ignition) wire needs to be connected to the **red** (input) cable for the BCDC1212S to function correctly (see [page 20](#)).

If your trailer plug's 12V auxiliary power pin is permanently powered and does not isolate when the vehicle is not running (ignition isolator or relay) the BCDC1212S does not require a **blue** wire connection.

If your trailer plug's 12V auxiliary power pin is isolated (not powered) when the vehicle is not running, the BCDC1212S required the **blue** wire to be connected to the **red** cable.

COMMON GROUND

Before planning wiring, consider that the BCDC1212S, auxiliary battery, start battery and solar panel/s must all share a common electrical ground to correctly charge from both inputs. This is typically achieved by connecting all grounds to the vehicle body.

AUXILIARY BATTERY LOAD CURRENT

Before wiring the auxiliary battery system, determine the loads to be powered and the total current to be drawn from the battery. This affects the load cable gauge and load fuse rating.

FIXED OR REMOVABLE

Determine if your install requires connections to be permanent or easily disconnected — this influences the connector choice. Soldered butt splice connectors are more suitable for fixed wiring while Anderson™ plugs are more suitable when disconnection is required, such as with portable battery boxes, trailers and portable solar panels. Below are examples of fixed and portable system setups.

Figure 3: Fixed Auxiliary Battery System

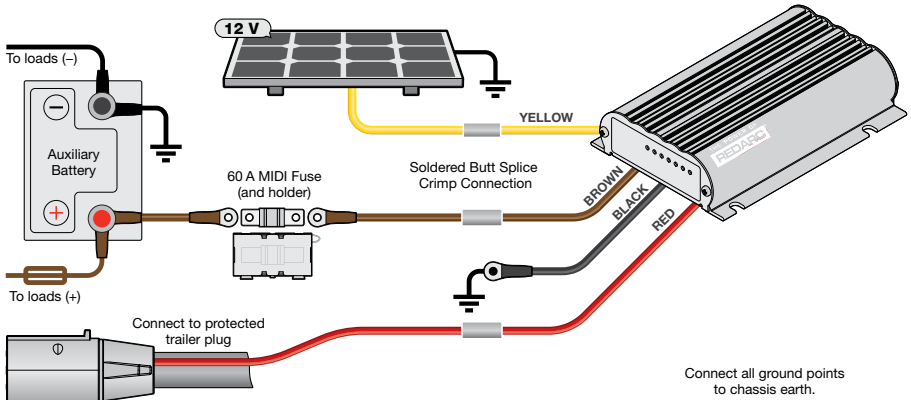
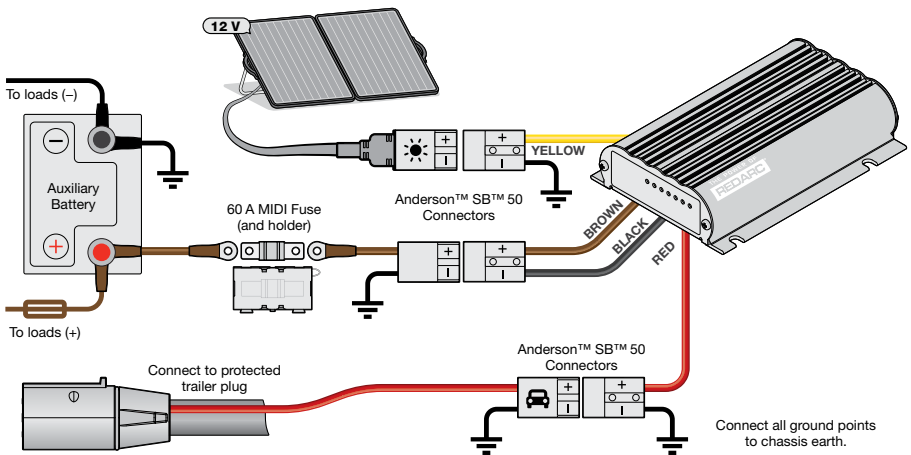

Figure 4: Portable Auxiliary Battery System



INSTALLATION – MOUNTING

MOUNTING REQUIREMENTS

⚠ CAUTION: The heatsink can reach around 60°C (140°F) (this is normal and safe operation when the Unit deliver's full power or run in hot conditions). The location to install the Unit should prevent contact with the users of the vehicle and not be in contact with highly flammable material. The Unit will operate optimally below 55°C (130°F) with good airflow. At higher temperatures the Unit will de-rate output current up to 80°C/175°F at which point the Unit will turn OFF.

IMPORTANT: The BCDC1212S must not be mounted in the engine bay of a vehicle. Moisture ingress and heat build up may damage the Battery Charger.

- The BCDC1212S Battery Charger is designed for installation within the vehicles cabin or in a similarly protected environment such as in a ute canopy, caravan or battery box.
- The Battery Charger should be mounted as close as possible to the auxiliary battery, with no more than 1 m (3'3") of cable length from the Unit to the auxiliary battery.
- Mount securely to a structural surface that can support the Battery Charger and the cable connections. Do not mount on moveable parts.
- The Battery Charger can be mounted in any orientation ensuring that the LED indicators are visible and accessible.
- The mounting surface must be flat and safe to drill — check the reverse side before drilling.
- If installing the Battery Charger in an enclosed space, make sure to leave adequate venting and clearance around all sides of the Unit.

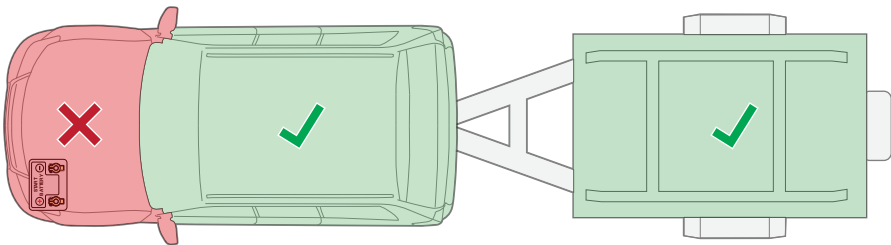

MOUNTING INSTRUCTIONS

MOUNTING HARDWARE

Do not use adhesives or adhesive tape to mount the Battery Charger.

When mounting the Battery Charger, any M6 fasteners with washers may be used as long as:

- They are suitable for the selected mounting surface and;
- They have a clearance-fit through the mounting points on the Battery Charger.

MOUNTING STEPS

⚠ WARNING

Use suitable Personal Protective Equipment when operating power tools.



All four mounting points must be used to mount the Battery Charger.

1. If clearance/pilot holes need to be drilled, place the Battery Charger in its final position and carefully mark the centre of each mounting point.
2. Remove the Battery Charger and drill clearance/pilot holes. De-burr the drilled holes and clear away swarf. Touch up any bare metal surfaces that have been exposed with a rust-inhibitor (e.g. primer).
3. Fasten the Battery Charger in place using four M6 fasteners with washers.

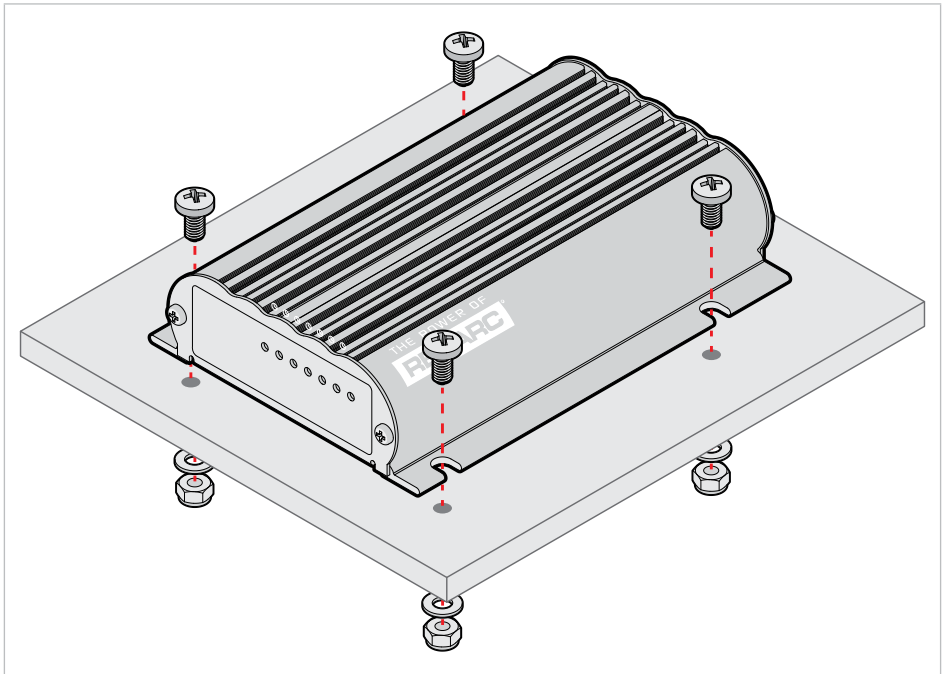

INSTALLATION – WIRING

CABLE ASSEMBLY

⚠ CAUTION: Failure to make a good reliable connection may result in breakdown of the wire insulation and cause a short circuit, or worst case a fire. REDARC recommend this activity be undertaken by an appropriately trained person.

The BCDC1212S's heavy gauge cables require good, low resistance electrical connections that will not degrade over time.

For extending the cables provided on the BCDC1212S, REDARC recommends using a soldered butt-splice crimp connection that is covered with heat shrink.

Crimping provides good mechanical connection, soldering provides a long lasting electrical connection and forming of the heat shrink is designed to prevent from any shorting/contact with your vehicle chassis.

1. Slide heatshrink over wire then insert wires into butt-splice. Keep heatshrink away from joint until after soldering is complete and has cooled.

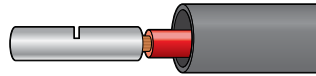

2. Crimp both wires to the butt-splice using single-indent type crimpers.

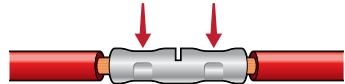

3. Solder the wires to the butt-splice. Ensure that a good connection is made.

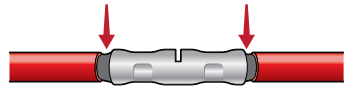

4. Wait for the butt-splice to cool, then slip heatshrink over the point and heat.



LUG ASSEMBLY

Cable lugs are commonly used when connecting cables between components of the auxiliary battery system.

REDARC recommend using heatshrink as it protects the cable and lug connections from harsh environments, sharp cutting edges and abrasion. Do not use standard pre-insulated Red/Blue/Yellow crimp connectors for connection of the BCDC1212S's 8 B&S cables as they are not rated to carry the required current.

1. Strip the end of the cable back enough to ensure the insulation does not enter the barrel of the lug when full inserted.



2. Slide heatshrink over the cable and insert the cable into the lug. Crimp the lug using a suitable crimping tool.



3. Slide the heatshrink to partially cover the lug, leaving the lug tongue exposed. Ensure there is adequate space around the stud hole for the Nyloc Locking Nuts.



4. Shrink the heat shrink.



SOLAR CONNECTORS

For cables that require disconnection, such as using a portable battery box or portable solar panels, Anderson™ SB™ 50 connectors may be used. These connectors are commonly used where the Battery Charger and auxiliary battery is mounted in a battery box or in a trailer where it must be easily disconnected from the vehicle.

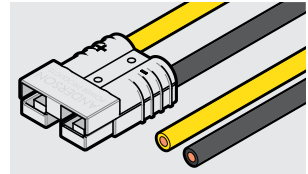

To ensure a secure connection into the Anderson plug contacts, cables smaller than 8 B&S may need the exposed wire folded over on itself for a snug fit in the contact before crimping.

When crimping any of these connector types, REDARC recommends using a ratcheting or hydraulic crimp tool as well as using heat shrink to prevent and shorting/contact with other components.

CABLE CONNECTIONS

NOTE: Damage to cabling can cause failure of the BCDC and vehicle electrical systems. Ensure cabling is clear of sharp edges or moving parts, and have enough slack to allow for flexing. REDARC recommend using cable ties and conduit or split tubing to manage cabling.

OUTPUT AUXILIARY BATTERY – BROWN CABLE

Mount a 60A fuse in close proximity to the auxiliary battery, then connect a cable (no more than 100 mm (3.9") in length) to one end of the fuse and to the positive (+) terminal of the auxiliary battery.

Connect the **brown** (output) cable to the other end of the fuse, ensuring that the cable length is at maximum 1 m (3'3") long.

Figure 5: Connecting the Brown Cable

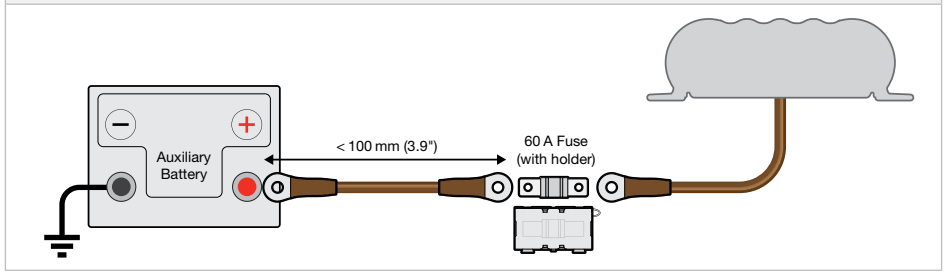

COMMON GROUND – BLACK CABLE

Connect the **black** (ground) cable to a ground point, such as a ground stud on the metal of the bodywork.

The **black** (ground) cable must be connected to a ground point that forms a common ground with both the auxiliary and start battery.

Table 3: Connecting the Black Cable

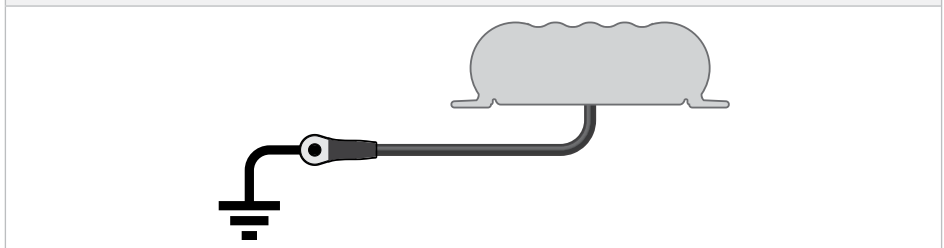

CHARGE PROFILE SELECTION – ORANGE WIRE

⚠ CAUTION:

- Check the manufacturer’s data for your battery and ensure that the Maximum voltage of the Charging Profile you select does not exceed the manufacturer’s recommended maximum charging voltage. If the Maximum voltage is too high for your battery type, select another Charging Profile.
- When using the BCDC1212S to charge a Lithium Iron Phosphate battery, only batteries that have an inbuilt battery management system featuring under and over voltage protection and cell balancing are suitable.
- The Heated Lithium (H) charging profile should only be used with lithium batteries that feature a functioning heating element. If unsure, the standard Lithium (Li) charging profile must be used. Using the wrong charging profile may damage your lithium battery.

Connect the **orange** (charge profile) wire to set the maximum output voltage to suit your selected Charge Profile. If required to leave the **orange** (charge profile) wire disconnected tape over the end of the wire.

Refer to [Table 4](#) to select the correct profile for your installation configuration.

Table 4: Charge Profile Selection for Cabin Installation

Battery Type	Charge Profile (25°C / 75°F)	Maximum Battery Voltage Specification
AGM/Gel	A	14.6V
Standard Lead Acid /Calcium	B	15.0V
Heated Lithium	H	14.2V (LiFePO ₄)
Lithium	Li	14.2V (LiFePO ₄)

Figure 6: Setting the Maximum Voltage (Orange wire)

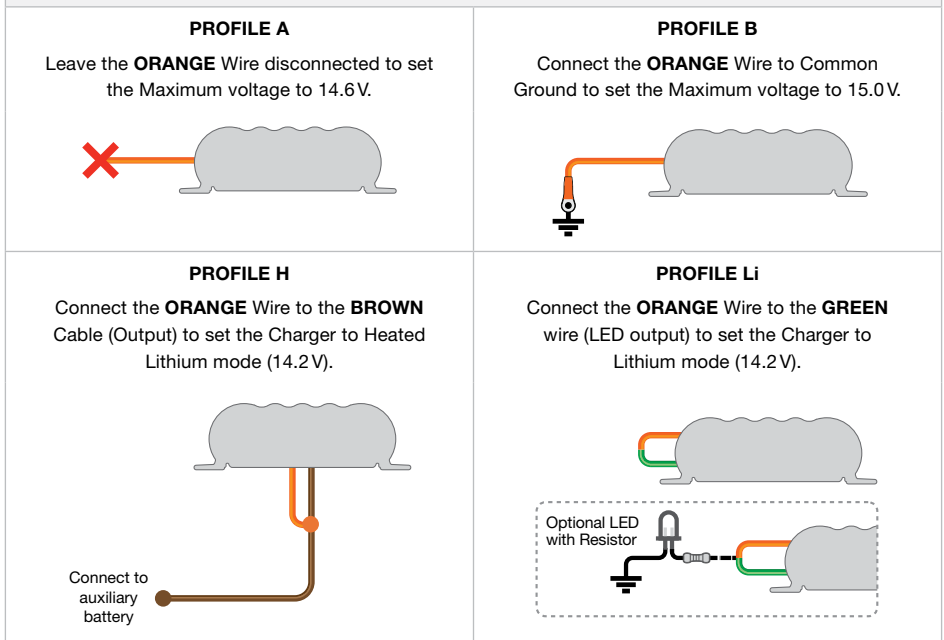

START BATTERY/VEHICLE IGNITION CONNECTION – RED/BLUE CABLE

RED CABLE CONNECTION

The **red** (input) cable can be connected directly to the trailer plug's 12V auxiliary power pin, provided that towing harnesses and connectors are suitably rated (see CAUTION on page 10).

BLUE WIRE CONNECTION

Start Safe — If the 12V auxiliary power supplying the BCDC1212S's red wire is permanently powered and will not isolate when the vehicle is not running (ignition isolator or relay) leave the **blue** wire disconnected. This will set the BCDC1212S to the standard voltage settings (see Table 5).

Max Charge — If the 12V auxiliary power supplying the BCDC1212S's red cable is isolated (not powered) when the vehicle is not running, connect the **blue** wire to the **red** cable. This will set the BCDC1212S to the low voltage setting and can increase the charging performance (see Table 5).

Figure 7: Connecting the red cable and blue wire

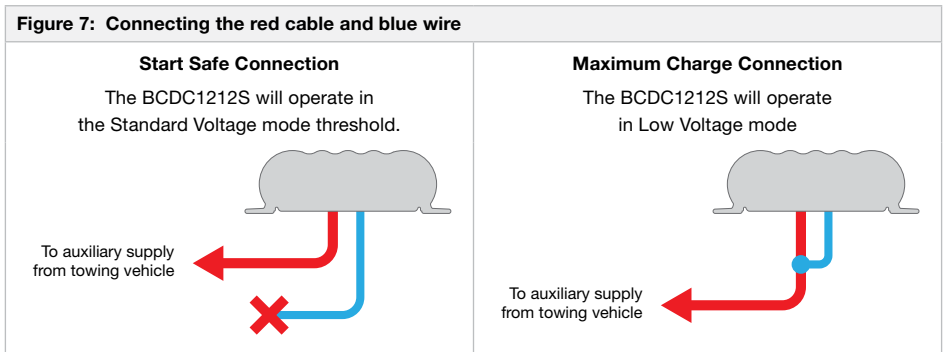

Table 5: Input Mode Charging Thresholds

Mode	Blue Wire Connection	12V Input Thresholds		24V Input Thresholds	
		ON above	OFF below	ON above	OFF below
Standard	Not connected	12.9V	12.7V	25.8V	25.4V
Low Voltage	Vehicle Ignition	12.0V	11.9V	24.0V	23.8V

In some applications the BCDC could deplete the start battery to 11.9V ±100mV or 23.8V ± 100mV for 12V and 24V vehicles respectively.

INSTALLATION USING A RELAY

An ignition switched relay can be used in situations where the **blue** (ignition) wire is required but it is difficult to run an ignition feed all the way to the Battery Charger (e.g. when installed in a trailer or battery box).

A relay can be added on the **red** (vehicle input) cable of the Battery Charger and controlled by a vehicle ignition signal. This can provide a Vehicle Input feed that is only on when the ignition is on. Connecting the **blue** wire to the BCDC1212S's **red** wire will enable the Battery Charger to charge the auxiliary battery in 'Low Voltage Mode' as demonstrated below.

For 12V applications, REDARC recommends the RK1260 Relay Kit that includes all components required.

Figure 8: Installation Using a Relay

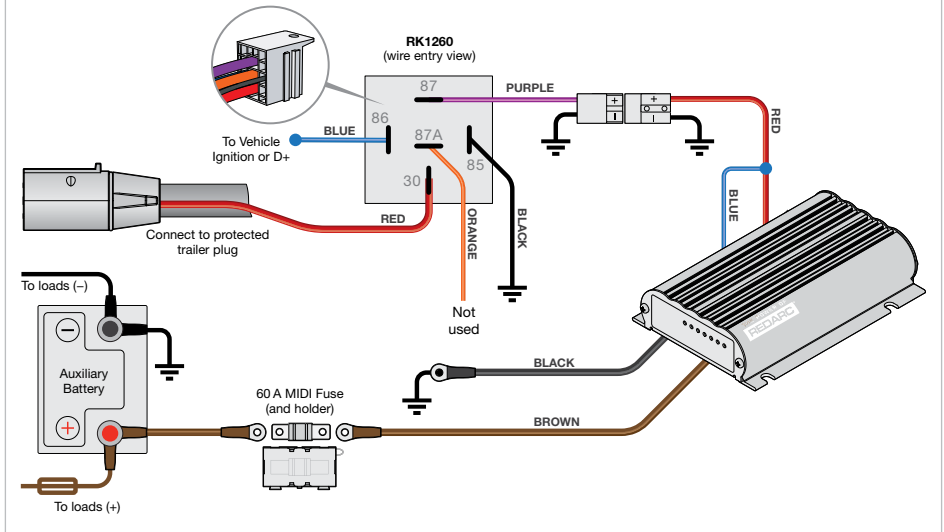

SOLAR PANEL(S) — YELLOW CABLE

IMPORTANT: DO NOT connect solar panels that have inbuilt regulators. The BCDC1212S has an inbuilt regulator that may not function correctly if regulated solar panels are connected.

NOTE: Most residential solar panels are not suitable for use with BCDC as they have an open circuit voltage that exceeds the 32V limit of the BCDC1212S input.

Use the yellow wire to connect the BCDC1212S to your solar panel using appropriate connector types based on your setup. See "[Connecting Multiple Solar Panels](#)" (page 23) for guidance when wiring multiple solar panels.

Figure 9: Connecting the Red Cable

Fixed Solar Panel Example

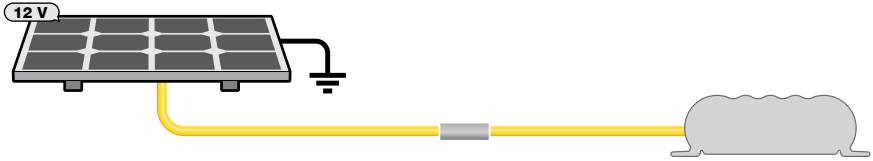

Portable Solar Panel Example

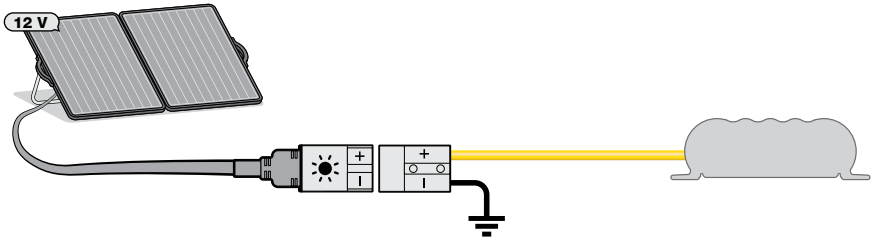

CONNECTING MULTIPLE SOLAR PANELS

The BCDC1212S can be connected to a solar panel array with a greater wattage than the BCDC's Maximum Output Power Rating (600W) ensuring that the correct cable size is used. The Battery Charger will automatically limit power going to the Unit if the panels supply more than the maximum wattage needed.

While output power may be limited in peak solar conditions, having this additional solar panel wattage is beneficial for solar power availability when conditions are sub-optimal. This will allow the BCDC1212S to charge more effectively earlier in the day and later into the night when solar irradiance is lower, panels are shaded or they cannot be angled directly towards the sun.

When connecting multiple 12V solar panels, it is important to connect them in parallel. Connecting in parallel ensures the output voltage remains the same while increasing the overall power output of the array. Ensure the select cable sizing is capable of carrying the maximum current of both panels combined.

Figure 10: Connecting solar panels in parallel

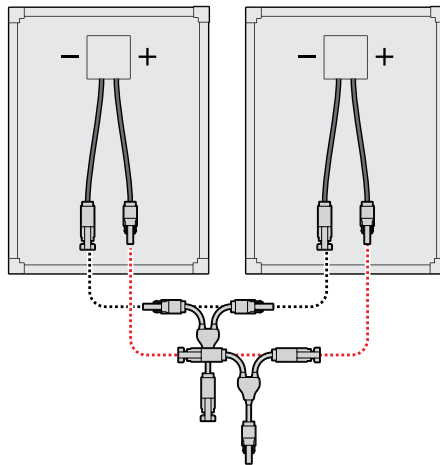

Example using MC4 Connectors.

OPTIONAL LED – GREEN WIRE

The **green** (optional LED) wire is provided to either connect an external LED (optional) when using A and B battery profiles or to connect to the **orange** (charge profile) wire for Li profile selection.

If the **green** wire is connected to an LED, it will function as an indicator light to let you know the BCDC is charging. If used, this external LED is either OFF when the BCDC is not charging or ON when the BCDC is charging. If the LED begins to FLASH see [page 26](#).

Only connect the **green** wire to the **orange** (charge profile) wire when using a Lithium profile battery, connecting these wires together sets the BCDC1212S to Lithium mode.

NOTE: If using an Optional LED, use a standard 12V LED with an integrated resistor (12V = 1kΩ or 24V = 2.2kΩ). A basic 3V LED will not operate correctly if installed.

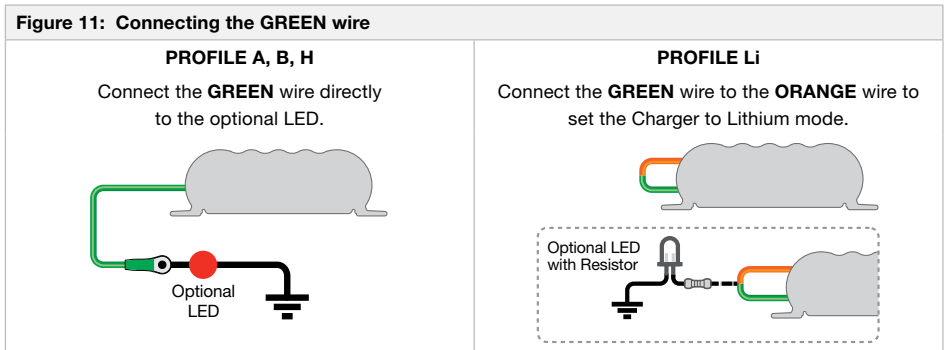

MAINTENANCE

Regularly check your BCDC setup and make sure wiring and cable connections are secure to avoid damaging the BCDC1212S, the auxiliary battery and the vehicle's start battery.

TROUBLESHOOTING

There are no LEDs ON at all.

This indicates that there is no battery connected to the brown (output) cable AND the red/yellow (vehicle input/solar) cables of the Charger are not connected.

1. Check all wiring to the Charger and battery, particularly the black (ground) cable.
2. Check fuses are intact and properly connected.

If the problem persists, contact your local Auto-Electrician.

The Charge Profile LED is flashing.

The Unit is in standby, this indicates:

- There is no valid charging source, therefore, the input is below the turn on threshold (see [page 27](#)).
 - There is no connection to the auxiliary battery.
1. Check that the red (vehicle input) cable and/or yellow (solar) cable are electrically connected.
 - The red (vehicle input) cable should connect directly to the Vehicle battery positive terminal via an adequately rated fuse.
 - The yellow (solar) cable should connect directly to the Solar Panel positive terminal/wire.
 2. Check that the black (ground) cable is connected to the auxiliary battery and common ground and/or the solar panel negative terminal/wire.
 3. Check all wiring to the auxiliary battery, particularly the black (ground) cable.
 4. Check fuses are intact and properly connected.

If the problem persists, see the relevant points following.

I have Solar connected but the Solar LED is OFF.

This indicates that the required turn ON conditions for this source have not been met. Either the Open Circuit Voltage at the yellow (solar) cable on the Charger is below 9V or there is not sufficient power available from the solar panel (due to poor light conditions or a faulty panel).

1. Is the sun out? No or low sunlight levels mean low power to your solar panels.
2. Check that the solar panel is not being shaded (by a tree etc.).
3. Check the voltage at the yellow (solar) cable, as close as possible to the Charger, is above 9V.
4. Check all wiring to the solar panel, particularly the black (ground) cable.
5. Ensure you have an unregulated solar panel.

Allow up to 2 minutes after any change for the Unit to recognise the input, if the problem persists, contact your local Auto-Electrician.

The BCDC is connected to the vehicle but the vehicle LED is OFF.

This indicates that the required turn ON conditions for this source have not been met OR the yellow (solar) cable is supplying the full input power requirements of the Charger.

With the blue (ignition) wire left unconnected, the voltage at the red (vehicle input) cable must be above 12.9V for a 12V installation or above 25.8V for a 24V installation.

With the blue (ignition) wire connected to Ignition, the Ignition must be on and the voltage at the red (vehicle input) cable must be above 12.0V for a 12V installation or above 24.0V for a 24V installation.

1. Check that the vehicle is running.
2. Check the voltage on the red (vehicle input) cable is above the required turn ON threshold for your installation (see "Turn On/Off Thresholds" (page 27)).
3. Check all wiring to the vehicle battery, particularly the black (ground) cable.
4. Check connection to the auxiliary battery and auxiliary battery ground connection

If the problem persists, contact your local Auto-Electrician.

ERROR CODES

In the event of a fault with the Unit installation, either battery or solar panel, ALL the LEDs on the Unit will flash to indicate the fault type.

LED State	Description
1 flash (followed by 3.5 second off)	Internal Hardware Fault
2 flash (followed by 3.5 second off)	Unit under temp fault
3 flash (followed by 3.5 second off)	Unit over temp fault
4 flash (followed by 3.5 second off)	Output Battery Fault (Volts too high)
5 flash (followed by 3.5 second off)	Input under voltage (Battery) ^{*3}
6 flash (followed by 3.5 second off)	Input over voltage (Battery or Solar panel) or the Solar Panel is connected in reverse polarity.

*3 If the Unit is being supplied power from the vehicle and solar simultaneously and ONE of those sources is undervoltage, that specific source LED will flash 5 times. If the Unit is being supplied power from the vehicle and solar with BOTH sources under voltage, OR if the Unit is being supplied power from one input only and that input is undervoltage, ALL LED's will flash 5 times.

TURN ON/OFF THRESHOLDS

Table 7: Turn On/Off Thresholds						
	Input	12V Vehicle Input		24V Vehicle Input		Solar
	Input Trigger Settings	Standard	Low Voltage	Standard	Low Voltage	N/A
Input Open Circuit Low voltage conditions ^{*1}	Turn ON ABOVE	12.9V	12.0V	25.8V	24.0V	9.0V
	Turn OFF BELOW	12.7V	11.9V	25.4V	23.8V	9.0V
Input Loaded Low voltage conditions ^{*2}	Stop Charging BELOW	12.2V	11.3V	24.4V	22.6V	N/A
	Turn OFF instantly BELOW	8.0V		8.0V		9.0V
	Turn OFF after 20 s BELOW	9.0V		9.0V		N/A
Input Overvoltage shutdown	Turn ON BELOW	15.5V		32.0V		32.0V
	Turn OFF instantly ABOVE	16.0V		32.5V		33.0V
	Turn OFF after 20 s ABOVE	15.6V		32.1V		N/A
Output Undervoltage shutdown ^{*1}	Shutdown if Output Battery < 0V					

^{*1}Tested every 100 seconds | ^{*2} Tested constantly

There is a maximum 20 second delay before the Charger will produce an output any time a source is introduced into the system, this allows the Unit to provide optimum input sharing and effective battery isolation.

FREQUENTLY ASKED QUESTIONS

The BCDC1212S turns ON at 12.9V (12V) and OFF at 12.7V (11.9V), but you say it operates down to 9V, explain?

The BCDC1212S will turn OFF for a split second every 100 seconds to measure the unloaded voltage at the battery. When the BCDC1212S turns off, it is not drawing any load from the start battery. No load means that there is no voltage drop over the cable run. This allows the BCDC1212S to measure the actual battery voltage, or the voltage at the battery. If this actual battery voltage is below 12.7V (11.9V), the BCDC1212S will turn OFF. At any other time during the charging process if the voltage at the BCDC1212S drops below 9V, the BCDC1212S will turn OFF.

How does the BCDC1212S charge an auxiliary battery at 14V when it only gets 9V in?

The BCDC1212S can act as both a reducer and a booster, so it can operate from a voltage of above, equal to or below the desired output voltage. The Unit is also microprocessor controlled allowing it to output a REDARC proprietary charging algorithm independent of the input. This allows the Unit to charge specific to the battery type even if the input voltage is low due to voltage drop.

What does the Charger do if the temperature around it rises above its operating temperature?

As the temperature of the BCDC1212S rises above a certain level the current capacity of the output is decreased gradually in order protect both the battery and the BCDC1212S Unit.

If I use the BCDC1212S to charge my auxiliary battery do I still need to install a battery isolator?

The BCDC1212S incorporates the functionality of a battery isolator, it will turn ON and start charging when it senses that the vehicle has started and similarly it will turn OFF when the vehicle is turned OFF.

I've heard that you shouldn't charge two batteries of different chemistries from the same source, will I have any problems charging my AGM or Gel auxiliary battery from my Lead Acid start battery?

The BCDC1212S does not 'link' the batteries together like a battery isolator does, it is a DC-DC Battery Charger. The output from the Unit is tailored specifically to the selected output battery type, and therefore allows the optimal charging of the auxiliary battery, no matter what chemistry your start battery is.

My BCDC1212S is setup for 12V Alternator input but will not start when the vehicle is turned On, I've followed the trouble shooting guide and the setup is fine, what's the problem?

The most likely cause of this issue is that the BCDC1212S is somehow stuck in 24V mode. Try disconnecting the red (vehicle input) cable and the brown (output) cable and then reconnecting it. If the problem persists, contact REDARC.

Can the BCDC1212S charge from Solar and Vehicle power at the same time?

Yes. The BCDC1212S will always attempt to supply power from the solar source first (when available) and will supplement this input with power from the vehicle source (when available).

Can the BCDC1212S operate with only a single power source input?

Yes. The BCDC1212S will operate as a stand-alone solar regulator when only Solar (YELLOW wire) is connected or it will operate as a DC Charger when only the red (vehicle input) cable is connected.

SPECIFICATIONS

Specifications are subject to change without notice.

Part Number	BCDC1212S			
Continuous Solar Rating	40 A			
Maximum Current Rating	55 A			
Continuous Vehicle Rating	12 A			
Vehicle Input Fuse Rating	23 A / 30 A (Not supplied)			
Maximum Output Power	600 W			
Vehicle Input Voltage Range^{*1}	9 to 32 V			
Solar Input Voltage Range^{*1}	9 to 32 V (unregulated only)			
Output Battery Type	Standard Lead Acid, Calcium content, Gel, AGM or LiFePO ₄ type only			
Charging Profile	A	B	H	Li
Maximum Voltage^{*1}	14.6 V	15.0 V		14.2 V
Float Voltage^{*1}	13.3 V			13.6 V
No Load Current	< 100 mA			
Standby Current	< 8 mA			
Standard Lead Acid Battery Temperature Behaviour	Charging Profile: A/B Output Battery > 10.5 V		-20°C to +80°C (-4°F to +176°F)	
	Charging Profile: A/B Output Battery < 10.5 V		0°C to +80°C (32°F to +176°F)	
Lithium Battery Temperature Behaviour	Charging Profile: H LiFePO ₄ Output Battery		-20°C to +80°C (-4°F to +176°F)	
	Charging Profile: Li LiFePO ₄ Output Battery		0°C to +80°C (32°F to +176°F)	
Minimum O/P Battery Volts	0.1 V			
Weight	900 g (31.7 oz)			
Dimensions (L x W x H)	165 x 120 x 37 mm (6.5" x 4.75" x 1.47")			
Warranty	2 years			
Regulatory Compliance	RCM, CE, UKCA, RoHS, FCC, CAN ICES-003(B)/NMB-003(B), E-Mark UNECE R10			

*1 Voltages Specified are ± 100 mV.

FCC DECLARATION

This device complies with Part 15 of the FCC Rules. Operation is subject to the following two conditions.

(1) This device may not cause harmful interference, and

(2) this device must accept any interference received, including interference that may cause undesired operation.

NOTE: This equipment has been tested and found to comply with the limits for a Class B digital device, pursuant to part 15 of the FCC Rules. These limits are designed to provide reasonable protection against harmful interference in a residential installation. This equipment generates, uses and can radiate radio frequency energy and, if not installed and used in accordance with the instructions, may cause harmful interference to radio communications. However, there is no guarantee that interference will not occur in a particular installation. If this equipment does cause harmful interference to radio or television reception, which can be determined by turning the equipment off and on, the user is encouraged to try to correct the interference by one or more of the following measures:

- Reorient or relocate the receiving antenna.
- Increase the separation between the equipment and receiver.
- Connect the equipment into an outlet on a circuit different from that to which the receiver is connected.
- Consult the dealer or an experienced radio/TV technician for help.

WARRANTY

LIMITED WARRANTY

For full warranty terms and conditions, visit the Warranty page of the REDARC website:
www.redarcelectronics.com/warranty

Australia, New Zealand, UK & Europe

REDARC Electronics Pty Ltd
23 Brodie Road (North),
Lonsdale SA 5160
Australia

North America

REDARC Corporation
1701 Northwest Highway, Suite 100
Grapevine TX
76051
USA

Australia +61 8 8322 4848
New Zealand +64-9-222-1024
UK & Europe +44 (0)20 3930 8109

USA +1 (704) 247-5150
Canada +1 (604) 260-5512
Mexico +52 (558) 526-2898

IMPORTER CONTACT INFORMATION

UK: Ozparts UK Ltd, 1 Prospect Place, Pride Park, DE24 8HG, Derby, UK

Europe: Ozparts Sp. z o. o. Sp. kom., Slowackiego 32/5, 87–100 Torun, Poland

For written request please email power@redarcelectronics.eu

CHECKING THE PRODUCT SERIAL NUMBER

The Product Serial Number is located on the Main Unit and on the product packaging.

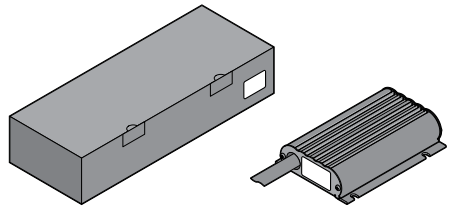

CE REDARC Electronics Pty Ltd
23 Brodie Road (North), Lonsdale South Australia 5160, Australia

Design and specifications are subject to change without notice | Copyright © REDARC Electronics Pty Ltd. All rights reserved
REDARC®, THE POWER OF REDARC®, and BCDC® are trademarks of REDARC Electronics Pty Ltd.

Tech Support
1300 REDARC

Head Office
+61 8 8322 4848

New Zealand
+64 9 222 1024

UK & Europe
+44 (0)20 3930 8109

USA
+1 (704) 247 5150

Canada
+1 (604) 260 5512

Mexico
+52 (558) 526-2898

redarcelectronics.com

THE POWER OF
REDARC®