

THE POWER OF

**REDARC**<sup>®</sup>

# RK1260

12V, 60A Changeover Relay Kit

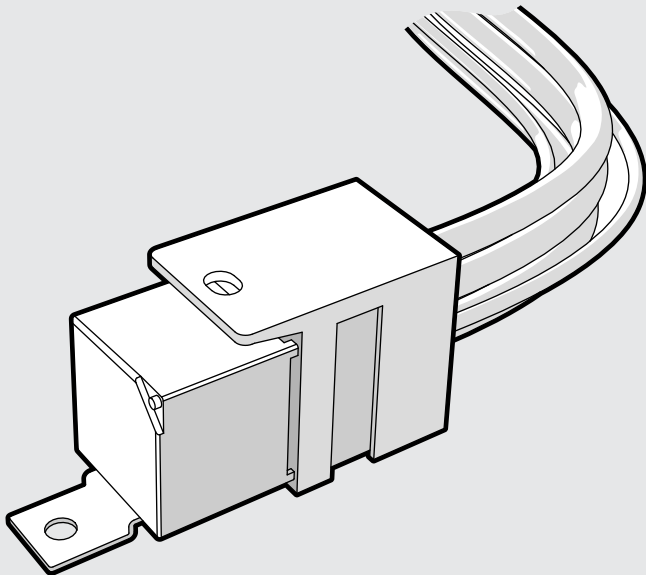

# WIRING THE RK1260

The RK1260 has many applications as a generic relay kit with contacts rated for 12 V up to 60 A. The coil is rated for 12 V with an engage voltage 8.4 V and disengage voltage of 2.4 V. The relay is sealed to IP67.

## NOTICE

Mount the RK1260 on a flat surface away from heat sources.

## USING THE RK1260 TO SUPPLY AN IGNITION SOURCE TO A BCDC

The RK1260 Relay Kit can be used in situations where it is difficult to run ignition feed all the way to a BCDC® (e.g. Installed in a trailer).

In order to work with variable-voltage type alternators (Smart Alternators), BCDC® chargers require an ignition input. This must receive starter battery voltage when the engine is running, and either be disconnected or connected to ground (GND) when the engine is turned off.

- ▶ For a trailer installation where the connection between trailer and tow vehicle will be temporary, an Anderson SB50 (shown in Figure 1) or other connector with a suitable current and voltage rating can be used.
- ▶ In applications where the installation is permanent it is recommended that the butt-splices supplied with the RK1260 be used (see Figure 2).

**Figure 1:** Wiring the RK1260 for a trailer application

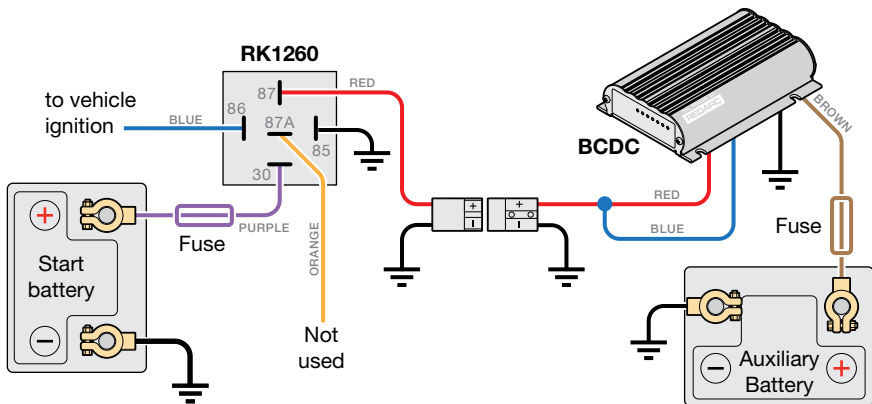

**Figure 2:** Crimping using butt-splices

1. Slide heatshrink over wire then insert wires into butt splice. Keep heatshrink away from joint until after soldering is complete and has cooled.
2. Crimp both wires to the butt splice using indent type crimpers.
3. Solder the wires to the butt splice. Ensure that a good connection is made.
4. Wait for the butt splice to cool, then slip heatshrink over the joint and heat.

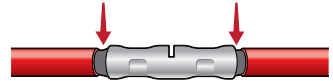
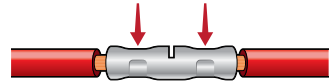
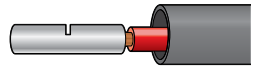

### **⚠ WARNING**

The relay and base are designed to form a tight connection. This is to ensure a secure connection for carrying the high current required between the relay pins and base terminals. Once the relay is installed, it is not designed to be removed on a regular basis.

Check that all wire terminals remain secured within the relay base, and are fully connected after inserting the relay (see [Figure 3](#)).

**Figure 3:** Inserting the wires into the relay base

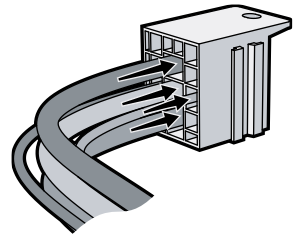

## **LIMITED WARRANTY**

For full warranty terms and conditions, visit the Warranty page of the REDARC website. Refer to the web address and contact details applicable to your region.

### **Australia, New Zealand & Europe**

[www.redarc.com.au/warranty](http://www.redarc.com.au/warranty)

REDARC Electronics Pty Ltd  
23 Brodie Road (North),  
Lonsdale SA 5160  
Australia

**Australia** +61 8 8322 4848  
**New Zealand** +64-9-222-1024  
**UK & Europe** +44 (0)20 3930 8109

### **North America**

[www.redarcelectronics.com/warranty](http://www.redarcelectronics.com/warranty)

REDARC Corporation  
c/o Shallco, Inc.  
308 Component Dr.  
Smithfield, NC 27577  
USA

**USA** +1 (704) 247-5150  
**Canada** +1 (604) 260-5512  
**Mexico** +52 (558) 526-2898

## CONTACT

**Australia** 1300 REDARC  
**New Zealand** +64 9 222 1024  
**UK & Europe** +44 (0)20 3930 8109

**redarc.com.au**

**USA** +1 (704) 247 5150  
**Canada** +1 (604) 260 5512  
**Mexico** +52 (558) 526-2898

**redarcelectronics.com**

THE POWER OF  
**REDARC**®



Pour accéder au manuel  
d'utilisation en Français



Para ver el manual  
en Español