

THE POWER OF

REDARC®

SOLAR

Solar Regulator

SRPA0120

SRPA0240

SRPA0360

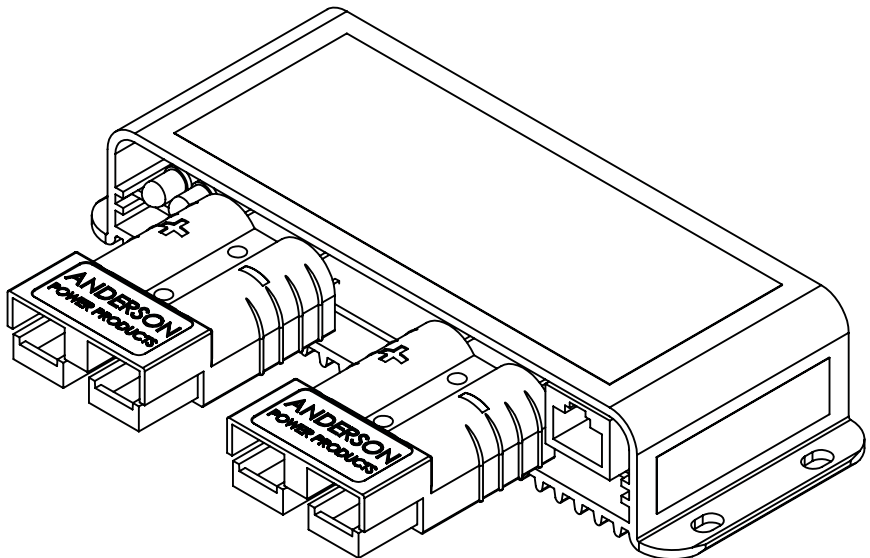

THE SOLAR REGULATOR

REDARC solar regulators ensure that the power supplied by your solar panels is at the right voltage to charge your lead acid house or auxiliary batteries. REDARC solar regulators are Pulse Width Modulated (PWM) controlled and incorporate automatic system voltage detection.

REDARC solar regulators come in 10 A, 20 A and 30 A models which are capable of charging either 12 V or 24 V battery systems. The SRPA regulators are supplied factory set to the AGM battery type setting; A REDARC remote monitor (SRPA-RM) is required to change the battery type.

WARNING & SAFETY INSTRUCTIONS

SAVE THESE INSTRUCTIONS — THIS MANUAL CONTAINS IMPORTANT SAFETY INSTRUCTIONS FOR REDARC SOLAR REGULATORS.

DO NOT OPERATE THE SOLAR REGULATOR UNLESS YOU HAVE READ AND UNDERSTOOD THIS MANUAL AND THE SYSTEM IS SETUP AS PER THESE INSTRUCTIONS. REDARC RECOMMENDS THAT ANY REGULATOR/CHARGER BE INSTALLED BY A SUITABLY QUALIFIED PERSON.

WARNING

RISK OF EXPLOSIVE GASES:

WORKING IN THE VICINITY OF A LEAD-ACID BATTERY IS DANGEROUS. BATTERIES GENERATE EXPLOSIVE GASES DURING NORMAL OPERATION. FOR THIS REASON, IT IS OF UTMOST IMPORTANCE THAT YOU FOLLOW THE INSTRUCTIONS EACH TIME YOU USE THE REGULATOR.

CAUTION

1. Solar Regulators should not be used by persons (including children) with reduced physical, sensory or mental capabilities, or lack of experience and knowledge, unless they are supervised or have been instructed on how to use the appliance by a person responsible for their safety. Children should be supervised to ensure that they do not play with the Solar Regulator.
2. Do NOT use the Solar Regulator to charge non-rechargeable batteries. Doing so may result in harm to the user and/or damage to the regulator and/or solar blanket. Only use the Solar Regulator for charging standard lead acid, calcium content, Gel & AGM type 12 V and 24 V batteries.
3. Over Charging Hazard. Failure to connect solar panel's negative wire directly to the regulator may result in overcharging the battery. The solar panel's negative wire must be connected directly to the regulator only.
4. Check the battery manufacturer's data for your battery and ensure that the voltage of the charging profile you select does not exceed the manufacturer's recommended maximum charging voltage. If the absorption and boost voltage for your battery type is too high, please select another charging profile. The Solar Regulator is not intended to supply power to a low voltage electrical system other than to charge a battery.
5. Electrical Hazard. Incorrect connection of batteries and solar panels in Parallel or Series can subject the regulator to high voltages that will damage the regulator. Ensure the recommended connections and sequences are followed and that the rated current, wattage and voltage of the regulator is not exceeded.
6. NEVER smoke or allow a spark or flame in vicinity of battery or engine. This may cause the battery to explode.

WARNING & SAFETY INSTRUCTIONS

PERSONAL SAFETY PRECAUTIONS

7. To assist with the safe operation and use of the Solar Regulator:
 - a. Wear complete eye protection and clothing protection. Avoid touching eyes while working near a battery.
 - b. If battery acid contacts your skin or clothing, remove the affected clothing and wash the affected area of your skin immediately with soap and water. If battery acid enters your eye, immediately flood the eye with running cold water for at least 10 minutes and seek medical assistance immediately.

NOTICE

The Solar Regulator will achieve best results when proper battery maintenance is regularly performed. This includes but is not limited to checking water and specific gravity levels of the battery.

CONTENTS

THE SOLAR REGULATOR	2
WARNING & SAFETY INSTRUCTIONS	2
1 INTRODUCTION	4
1.1 Dimensions	4
1.2 Regulator Function	4
2 THE SOLAR REGULATOR	5
2.1 Regulator Connection	5
2.2 LED Indication	5
2.3 Specifications	6
3 SYSTEM SETUP	7
3.1 Installation Notes	7
3.2 Fuse Protection	8
3.3 Accessories	9
3.3.1 SRPA-RM	9
3.3.2 REDARC Cable Range	9
4 SYSTEM WIRING	10
4.1 12 V Standard System	10
4.2 24 V Standard System	11
4.3 Wiring Multiple Panels in Parallel (12 V)	12
4.4 Wiring Multiple Panels of Different Types in Parallel (12 V)	13
5 WARRANTY	14

1 THE SOLAR REGULATOR

1.1 Dimensions

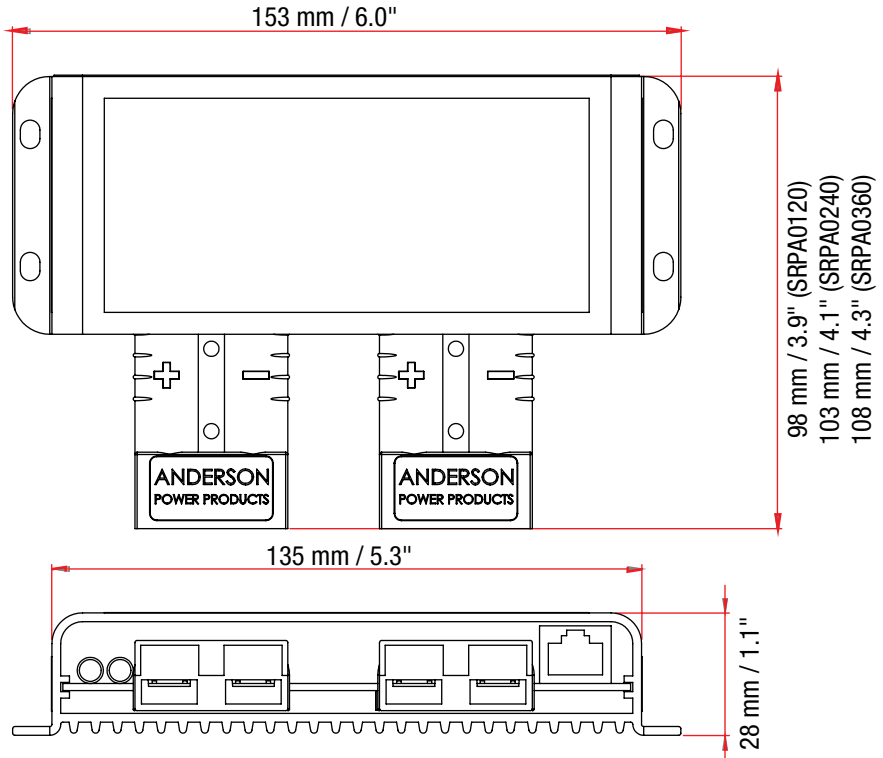

1 THE SOLAR REGULATOR

1.2 Regulator Function

The SRPA regulators are supplied factory set to the AGM battery type setting; A REDARC remote monitor (SRPA-RM) is required to change the battery type.

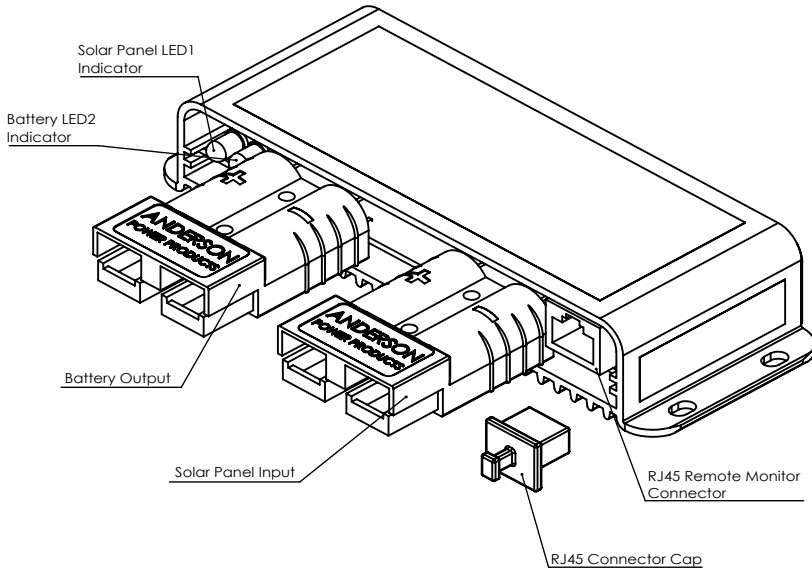

1.3 Regulator Connection

1. Connect to the battery first before the solar panel.
2. Connect to the Battery and Solar Panel via an Anderson™ SB™ 50, 50 A grey connector.
3. The REDARC Solar Regulator should be installed as close as possible to the battery it is charging.
4. Refer to the Installation notes in section 3.1 (on page 9) and System Wiring (page 11).
5. Caution: Incorrect connection of the battery or solar panel can damage the regulator, please confirm all wiring polarity before connection is made.

1 THE SOLAR REGULATOR

1.4 LED Indication

LED Status	On Solid	1 flash/second	Off	3 flashes/second
LED1 — Solar panel (Green)	Normal	Charging	No Charge	N/A
LED2 — Battery (Green)	Normal	Battery Full	N/A	Over voltage
LED2 — Battery (Red)	Over Discharge	N/A		
LED2 — Battery (Orange)	Under Voltage			
LED1 — Green LED2 — Red	N/A			System voltage error
LED1 — Green LED2 — Orange				Over temperature

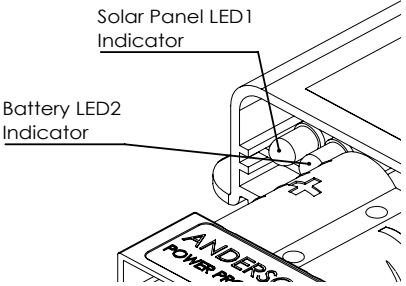
<p>LED1 flashing green — 1 flash/second</p> <p>The regulator is charging the battery and all functions are normal.</p>	<p>LED1 Green & LED2 Red — 3 flashes/second</p> <p>The regulator has a solar panel or battery connected producing a voltage outside the system limits, please remove and check the solar panel or battery voltage.</p>
<p>LED1 off</p> <p>There is no charge from the solar panel. Check the solar panel is connected correctly and the panel is in full sunlight.</p>	<p>LED1 Green & LED2 orange — 3 flashes/second</p> <p>The regulator internal temperature has exceeded 80°C / 176°F and will stop charging until the temperature is reduced.</p>
<p>LED2 flashing green — 1 flash/second</p> <p>The battery is full and all functions are normal.</p>	
<p>LED2 solid green</p> <p>The battery is connected and the voltage range is normal.</p>	
<p>LED2 solid orange</p> <p>The battery voltage is low.</p>	

2 SYSTEM SETUP

- If using more than one panel, ensure that all panels are situated near each other and are exposed to similar lighting conditions. Failure to do this may cause damage to the panels.
- If using multiple panels, it is highly recommended to ensure that they are identical.

⚠ CAUTION

OVER CHARGING HAZARD. FAILURE TO CONNECT SOLAR PANEL'S NEGATIVE WIRE DIRECTLY TO THE REGULATOR MAY RESULT IN OVERCHARGING THE BATTERY. THE SOLAR PANEL'S NEGATIVE WIRE MUST BE CONNECTED DIRECT TO THE REGULATOR ONLY.

ELECTRICAL HAZARD. INCORRECT CONNECTION OF BATTERIES AND SOLAR PANELS IN PARALLEL OR SERIES CAN SUBJECT THE REGULATOR TO HIGH VOLTAGES THAT WILL DAMAGE THE REGULATOR. ENSURE THE RECOMMENDED CONNECTIONS AND SEQUENCES ARE FOLLOWED AND THAT THE RATED CURRENT AND/OR VOLTAGE OF THE REGULATOR IS NOT EXCEEDED.

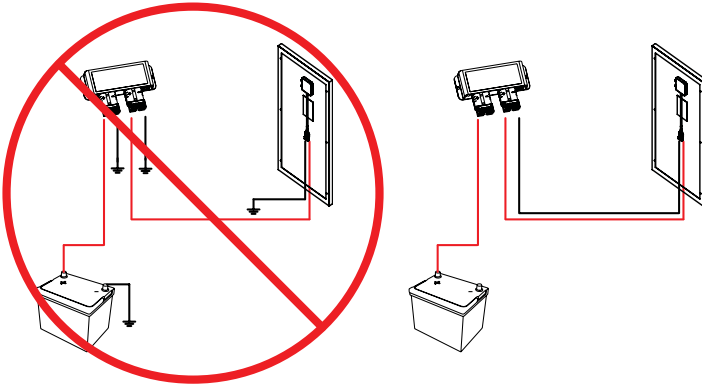

2.1 Fuse Protection

Fuse protection is required for wire and component protection in case of short circuit. Fuses are to be fitted as close as possible to the battery positive terminal.

REDARC recommend using MIDI style bolt down fuses as they ensure a low resistance connection. The REDARC FK40 and FK60 fuse kits are recommended.

Blade type fuses are not recommended as they can result in high resistance connection which causes excess heat and may damage the fuse holder and/or the wiring. Self-resetting circuit breakers are not recommended as they may trip prematurely due to the heat generated by the current flowing through the wires.

2 THE SOLAR REGULATOR

2.2 Specifications

System Voltage	12V			24V		
Battery Type selectable via remote monitor SRPA-RM	AGM (Default)	Standard Lead-Acid	Calcium	AGM (Default)	Standard Lead-Acid	Calcium
Absorption Voltage* Constant Voltage Stage	14.4 V	14.6 V	14.8 V	28.8 V	29.2 V	29.6 V
Equalise Charging Voltage	n/a	14.8 V	15 V	n/a	29.6 V	30 V
Equalise Time	2 hours			2 hours		
Absorption Time	3 hours					
Float Voltage*	13.6 V			27.2 V		
Solar Panel Input Range	16 V – 32 V			34 V – 50 V		
Battery Voltage Range	9 V – 16 V			18 V – 32 V		
Standby Current Draw	10 mA			4.5 mA		
Battery Charging Limit Voltage	16 V			32 V		
Boost Reconnect Charging Voltage	13.2 V			26.4 V		
Power Rating	120 W (SRPA0120) 240 W (SRPA0240) 360 W (SRPA0360)			240 W (SRPA0120) 480 W (SRPA0240) 720 W (SRPA0360)		
Current Limit	10 A (SRPA0120) / 20 A (SRPA0240) / 30 A (SRPA0360)					
Boost Charge	100% of available solar charge will be used until absorption voltage is reached.					
Charge Type and Operating Frequency	PWM 50Hz					
Charging Stage Switching	Switches on voltage setting					
Temp. Compensation	-30 mV / °C / 12 V (-16.7 mV / °F / 12 V)					
Terminals	Anderson™ Powerclaw™, 50 A					
Connector	Anderson™ SB™50, Grey					
Operating Temp.	-35°C to 55°C / -31°F to 131°F					

*Charge profile voltages will vary with change in temperature, as per temperature compensation rates.

ICES Declaration: CAN ICES-003 (B) / NMB-003(B)

3 SYSTEM SETUP

This device complies with part 15 of the FCC Rules. Operation is subject to the following two conditions:

1. This device may not cause harmful interference.
2. This device must accept any interference received, including interference that may cause undesired operation.

This equipment has been tested and found to comply with the limits for a Class B digital device, pursuant to part 15 of the FCC Rules. These limits are designed to provide reasonable protection against harmful interference in a residential installation. This equipment generates, uses and can radiate radio frequency energy and, if not installed and used in accordance with the instructions, may cause harmful interference to radio communications. However, there is no guarantee that interference will not occur in a particular installation. If this equipment does cause harmful interference to radio or television reception, which can be determined by turning the equipment off and on, the user is encouraged to try to correct the interference by one or more of the following measures:

- Reorient or relocate the receiving antenna
- Increase the separation between the equipment and receiver
- Connect the equipment into an outlet on a circuit different from that to which the receiver is connected
- Consult the dealer or an experienced radio / TV technician for help

Changes or modifications not expressly approved by (the party responsible for compliance) could void the user's authority to operate the equipment

3.1 Installation Notes

- Always connect the battery/s first (before the panel).
- Always ensure the connection to the battery terminals is sound, with as much surface contact between the battery terminal and the connection method (e.g. Alligator clips) as possible.
- The regulator should be installed as close as possible to the battery/s.
- Ensure that any non-REDARC Anderson™ plug terminals are soldered correctly or crimped with the correct Anderson™ crimping tool.
- Always check the manufacturer's data for your battery and ensure that the maximum voltage of the charging profile you select does not exceed the manufacturer's recommended maximum charging voltage. If the 'Maximum' voltage for your battery type is too high, please select another charging profile. SRPA-RM will be required to change from default setting.
- Care should be taken to not expose the regulator to moisture.
- For optimum operation, the regulator should be mounted in an environment where the temperature is normally below 45°C / 113°F and does not exceed 55°C / 131°F.
- Battery clip SRC0009 is intended for a portable short term connection and should not to be left connected permanently.

3 SYSTEM SETUP

3.2 Accessories

3.2.1 SRPA-RM

The SRPA-RM is an optional Remote Monitor for use with REDARC SRPA0120, SRPA0240 and SRPA0360 regulators.

The SRPA-RM is required to change the charging profile on the Regulator. By Default SRPA0120, SRPA0240 and SRPA0360 Regulators are set to AGM.

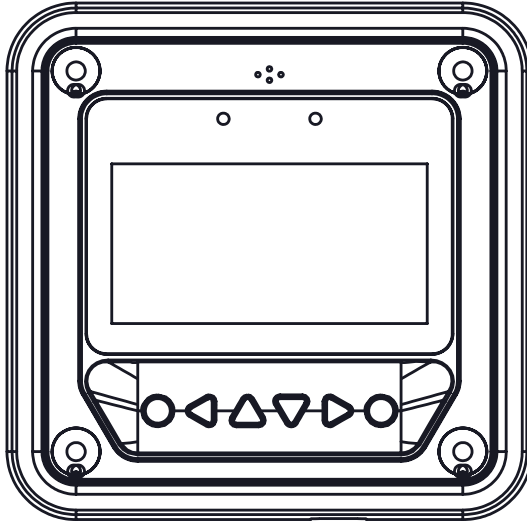

3.2.2 REDARC Cable Range

Part Number	Length	Description
SRC0019	10 m / 32.8 ft	Anderson™ to Anderson™ Cable
SRC0018	5 m / 16.4 ft	Anderson™ to Anderson™ Cable
SRC0009	1.5 m / 4.9 ft	Anderson™ to Battery Clip
SRC0010	1.5 m / 4.9 ft	Anderson™ to Battery Terminal
SRC0011	0.3 m / 1 ft	Series Anderson™ to Anderson™ Connector
SRC0012	0.3 m / 1 ft	Parallel Anderson™ to Anderson™ Connector
SRC0008	1.5 m / 4.9 ft	Anderson™ to Anderson™ Cable

4 SYSTEM WIRING

4.1 12 V Standard System

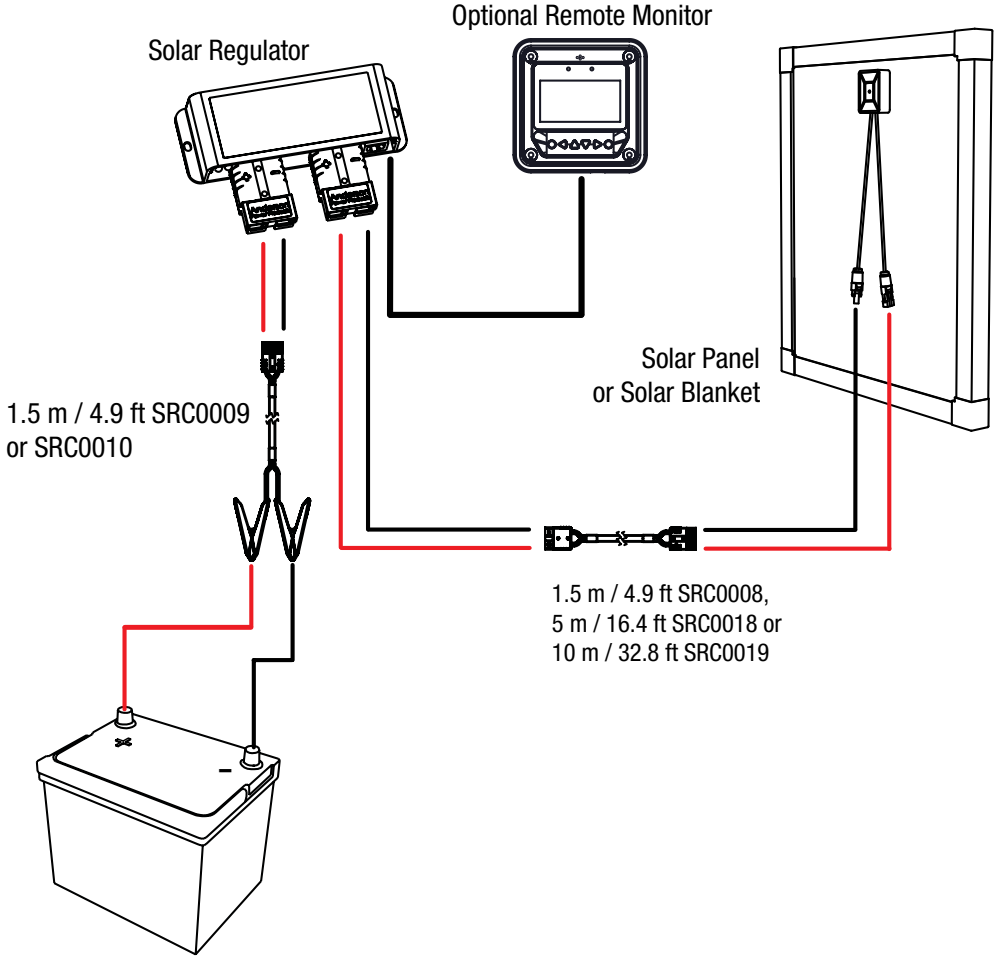

4 SYSTEM WIRING

4.2 24 V Standard System

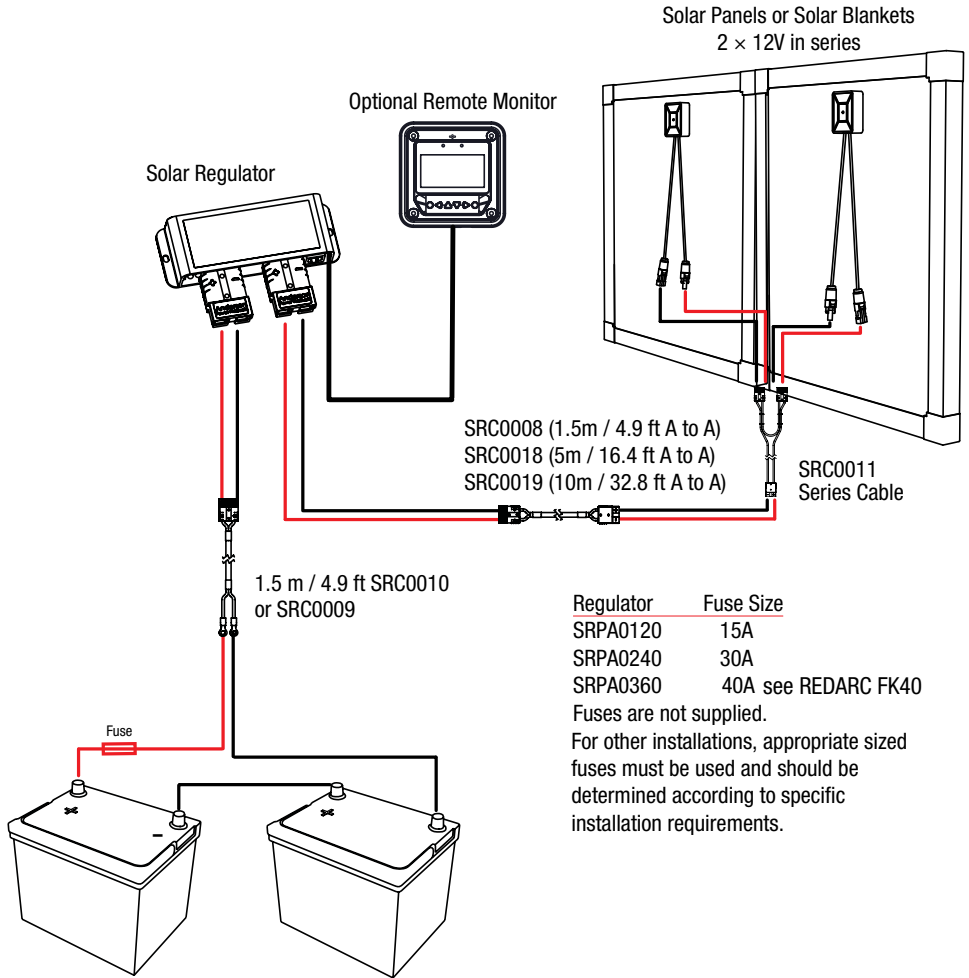

NOTICE

- Both panels used must be identical, mixing and matching may cause damage. The lowest rated current panel will dissipate heat if they are not matched.
- Both panels must be positioned next to each other at the same angle to receive identical illumination otherwise damage can be caused and/or batteries may not charge.

4.3 Wiring Multiple Panels in Parallel (12 V)

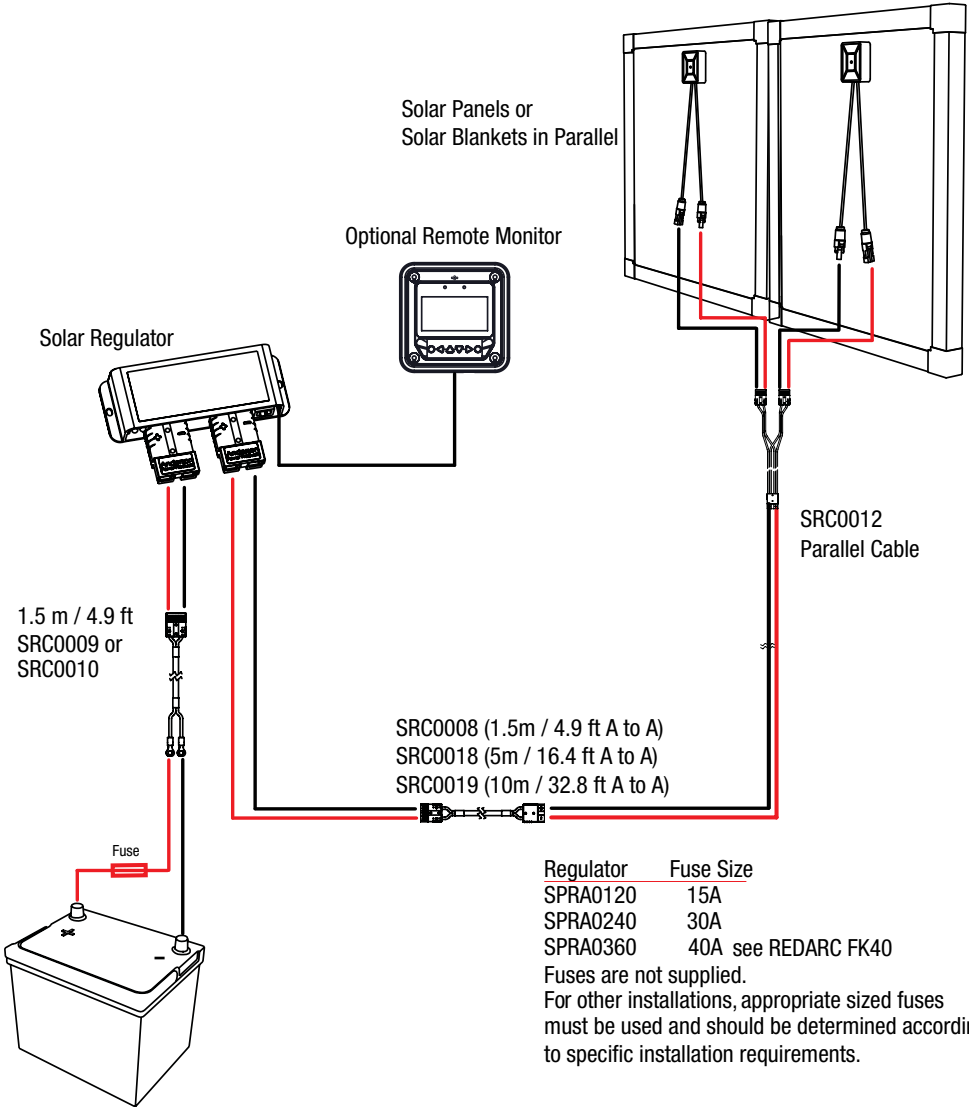

Limited Warranty

For full warranty terms and conditions, visit the link below or refer to the contact details applicable to your region.

Australia and New Zealand

www.redarc.com.au/warranty

REDARC Electronics Pty Ltd
23 Brodie Road (North),
Lonsdale SA 5160
Australia

Australia +61 8 8322 4848
New Zealand +64 9 222 1024
UK/Europe +44 (0)20 3930 8109

North America

www.redarcelectronics.com/warranty

REDARC Corporation
c/o Shallco, Inc.
308 Component Dr.
Smithfield, NC 27577
USA

USA +1 (704) 247 5150
Canada +1 (604) 260 5512
Mexico +52 (558) 526 2898

THE POWER OF

REDARC®

SOLAR

APP
Anderson Power Products®

© 2016 Anderson Power Products™,
Inc. All rights reserved.

Australia

power@redarc.com.au
www.redarc.com.au
+61 8 8322 4848

New Zealand

power@redarcelectronics.co.nz
www.redarcelectronics.co.nz
+64 9 222 1024

North America

power@redarcelectronics.com
www.redarcelectronics.com

United States

+1 (704) 247 5150

Canada

+1 (604) 260 5512

Mexico

+52 (558) 526 2898

UK/Europe

power@redarcelectronics.eu
www.redarcelectronics.eu
+44 (0)20 3930 8109

www.redarc.com.au