

THE POWER OF

REDARC®

ICMS-012

QuickFit X40 Integrated Power System

MODELS:

- ICMS-012-50
- ICMS-012-75
- ICMS-012-100
- ICMS-012-50-NA
- ICMS-012-75-NA
- ICMS-012-100-NA

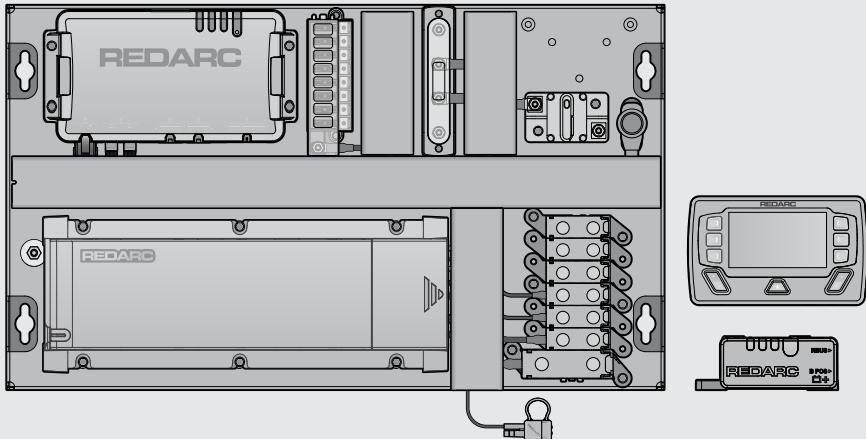

ICMS-012

QuickFit X40 Integrated Power System

The QuickFit X40 Integrated Power System is a fully integrated power management solution, engineered by REDARC to meet the demands of modern off-grid recreational vehicles, including caravans, motor-homes, and travel trailers.

Designed to create a truly smart RV experience, the QuickFit system, featuring REDARC's trusted RedVision Display, offers users the ultimate convenience. With RedVision®, users can spend more time enjoying their adventures and less time managing their vehicle's power.

The QuickFit includes the Manager Alpha® with RedVision® Display and Smart Battery Monitor, along with two TVMS Rogue Control Modules, offering a fully integrated, pre-wired solution in one box. Each system is pre-wired, precisely assembled, and rigorously tested by REDARC to ensure easy installation for manufacturers and consistent performance for end users. Supported by REDARC's industry-leading warranty and technical expertise, both OEMs and RV owners can trust that this system will elevate their off-grid experience to the next level.

FEATURES AND BENEFITS

- **Rapid Charge from Multiple Sources** — Quickly charge batteries from the vehicle's alternator, solar panels or mains power. Whether on the road or at a campsite, the QuickFit ensures users have continuous power for all their needs.
- **Start Battery Recovery** — If the tow vehicle or motorhome start battery runs flat, the QuickFit system allows users to recharge from the RV battery, ensuring they're never stranded and always have the means to get back on the road.
- **Centralised Vehicle Management** — Manage up to 20 switched loads from the RedVision Display. Users can easily control lighting, water pumps, and other accessories from one central hub, reducing complexity. Additionally, monitor up to 4 tank levels, giving users complete oversight of their water resources.
- **Power Distribution Simplified** — The system includes 8 blade fused outputs and 3 MIDI fused outputs, providing power for both constant loads and high-power devices like power jacks and compressors. Consolidating all power distribution onto a single board simplifies wiring and makes it easier for users to understand their RV's electrical system.
- **Smart Power Management** — The QuickFit can automatically switch off non-essential loads when battery levels are low, conserving energy for critical systems.
- **Smart Lighting Control** — With the press of a single button, users can turn on and off all interior and exterior lights, simplifying control. Lights can be configured to turn on at a preset dimming level, creating the perfect atmosphere for any environment.
- **Remote Control via RedVision App** — Using the RedVision App, users can remotely control their entire system via Bluetooth. From the comfort of their bed or camp chair, they can turn off lights, check battery levels, or monitor water tanks, adding an extra layer of convenience to life on the road.
- **Versatile Switch Inputs** — The system supports up to 16 switch inputs, allowing users to control various RV functions such as lighting, accessories, awnings, and water pumps from multiple switches mounted throughout the vehicle, offering flexibility and convenience.

CONTENTS

WARNINGS & SAFETY INSTRUCTIONS	4
OVERVIEW	6
Kit Contents.....	6
Parts of the ICMS-012.....	7
INSTALLATION – MOUNTING	8
Mounting Checklist – Before You Begin.....	8
Mounting the ICMS-012.....	9
Mounting the Display and Battery Monitor.....	10
Cable Pass-Through Holes.....	10
INSTALLATION – WIRING	11
System Layout.....	11
Wiring Diagram – As Supplied.....	12
Wiring Diagram – Typical Setup.....	13
Wiring Steps.....	14
1. Connect the Auxiliary Battery.....	14
2. Connect the Negative Busbar to Chassis Ground.....	15
3. Connect the Start Battery.....	15
4. Connect Ignition.....	16
5. Connect R-Bus Cables.....	16
6. Connect Solar.....	17
7. Connect Auxiliary loads.....	17
8. Configuration and Testing.....	20
TVMS Rogue Strain-Relief and Cable Management.....	20
System Strain-Relief and Cable Management.....	21
FULL-LENGTH INSTRUCTION MANUALS	22
TECHNICAL SPECIFICATIONS	22
WARRANTY	23

WARNINGS & SAFETY INSTRUCTIONS

SAVE THESE INSTRUCTIONS — this manual contains important safety instructions.

Do not operate the system unless you have read and understood this manual.

REDARC recommends that the products referenced in this manual be installed by a suitably qualified person.

Disclaimer: REDARC accepts no liability for any injury, loss or property damage which may occur from the improper or unsafe installation or use of its products.

SAFETY MESSAGE CONVENTIONS

Safety messages in this manual include a signal word to indicate the level of the hazard as follows:

⚠ WARNING: Indicates a potentially hazardous situation which, if not avoided, could result in death or serious injury to the operator or to bystanders.

⚠ CAUTION: Indicates a potentially hazardous situation which, if not avoided, may result in moderate or minor injury to the operator or to bystanders.

NOTICE: Indicates a situation that may cause equipment damage.

IMPORTANT SAFETY INSTRUCTIONS

⚠ WARNING

When using this product, basic precautions should always be followed, including the following:

1. These products should not be used for any medical purposes, life sustaining equipment, safety applications, or any application where equipment failure can cause injury, death, fires or any other hazard.
2. Do NOT put fingers or hands into the product.
3. Do NOT use the ICMS-012 if damaged or modified. Damaged or modified products may exhibit unpredictable behaviour resulting in fire, explosion or risk of injury.
4. No user serviceable parts inside. Do NOT attempt servicing this product.
5. **Risk of explosive gases:** Working in the vicinity of a lead-acid battery and Lithium-ion technologies is dangerous. Batteries may generate explosive gases during normal operation. Prevent flames and sparks, and provide adequate ventilation especially during charging.
6. To reduce risk of battery explosion, follow these instructions and those published by the battery manufacturer and manufacturer of any equipment you intend to use in vicinity of the battery.

PERSONAL PRECAUTIONS

7. Consider having someone close-by to come to your aid if you are working near a lead-acid battery.
8. Have plenty of fresh water and soap nearby in case battery acid contacts skin, clothing, or eyes.
9. Wear complete eye protection and clothing protection. Avoid touching eyes while working near battery. If battery acid contacts skin or clothing, wash immediately with soap and water. If acid enters eye, immediately flood eye with running cold water for at least 10 minutes and seek medical attention immediately.
10. **DO NOT** drop metal tools onto a vehicle battery. Doing so might cause the battery to spark or might short-circuit the battery or other electrical parts, which may cause an explosion.
11. **NEVER** smoke or allow a spark or flame in vicinity of battery or engine.

12. Remove personal metal items such as rings, bracelets, necklaces, and watches before working with a vehicle battery. A vehicle battery can produce a short-circuit current high enough to weld a ring or the like to metal, causing a severe burn.
13. Have servicing performed by a qualified repair person using only identical replacement parts. This will ensure that the safety of the product is maintained.
14. **RISK OF FIRE** — Do NOT install this product in the same compartment where flammable substances are stored, such as petrol/gasoline or Liquefied Petroleum Gas (LPG).
15. Incorrect handling or disassembly/reassembly may result in a risk of fire. Any attempt to disassemble/reassemble the ICMS-012, or make unapproved repairs or modifications will void the warranty and the user's authority to operate the ICMS-012.
16. DO NOT expose the ICMS-012 to temperatures beyond the published limits.
17. DO NOT operate the ICMS-012 beyond the published ratings. Doing so may result in damage to the ICMS-012, fire, explosion and burns/personal injury.
18. If any mechanism or part of the ICMS-012 becomes broken or damaged, discontinue use immediately.
19. Use suitable Personal Protective Equipment (PPE) when operating power tools.



▲ CAUTION

20. Selecting the wrong cable or fuse size could result in harm to the installer or user and/or damage to the battery or other equipment installed in the system. The installer is responsible for ensuring that all installer-supplied cables and fuses are the correct size and type (i.e. has physical performance properties and ratings suitable for the install conditions).
21. The system should not be used by persons under the age of 18, or those with reduced physical, sensory or mental capabilities or lack of experience and knowledge unless they are supervised and under instruction.
22. Cabling must be installed in protected areas away from heat sources, sharp objects or over/through parts of the vehicle that move during operation or maintenance. Supplementary protection such as conduit may be required, especially when installing or routing in the engine bay.
23. **DO NOT** use this product to control safety critical devices or those that could cause harm if operated remotely (for example fume exhaust fans or lifters). Only operate devices with moving parts when you have a clear line of sight to the moving parts.

OVERVIEW

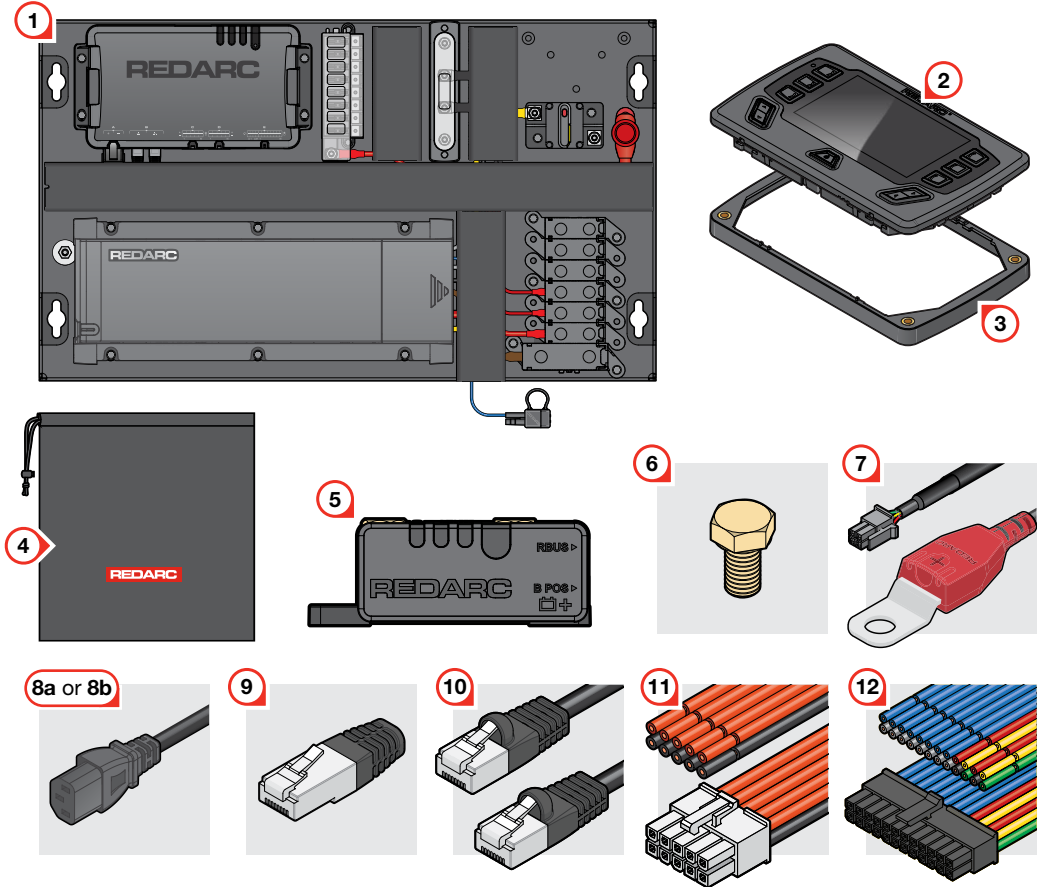

KIT CONTENTS

Ref.	Part	Qty.
1	ICMS-012 Integrated Module	1
2	4.3" Display (DISP4300)	1
3	Optional Mounting Spacer	1
4	Draw String Bag	1
5	Smart Battery Monitor (BSEN500)	1
6	M10 × 10 mm Alternative Terminal Bolt	1
7	Battery Sense Lead	1
8	a. AU Mains Cable — 1.8 m (5'11") b. NA Mains Cable — 0.9 m (3')	1
9	RJ45 R-Bus Terminating Resistor	1
10	RJ45 R-Bus Cable — 2 m (6'6")	2
11	Output Wiring Loom	4
12	Input Wiring Loom	2

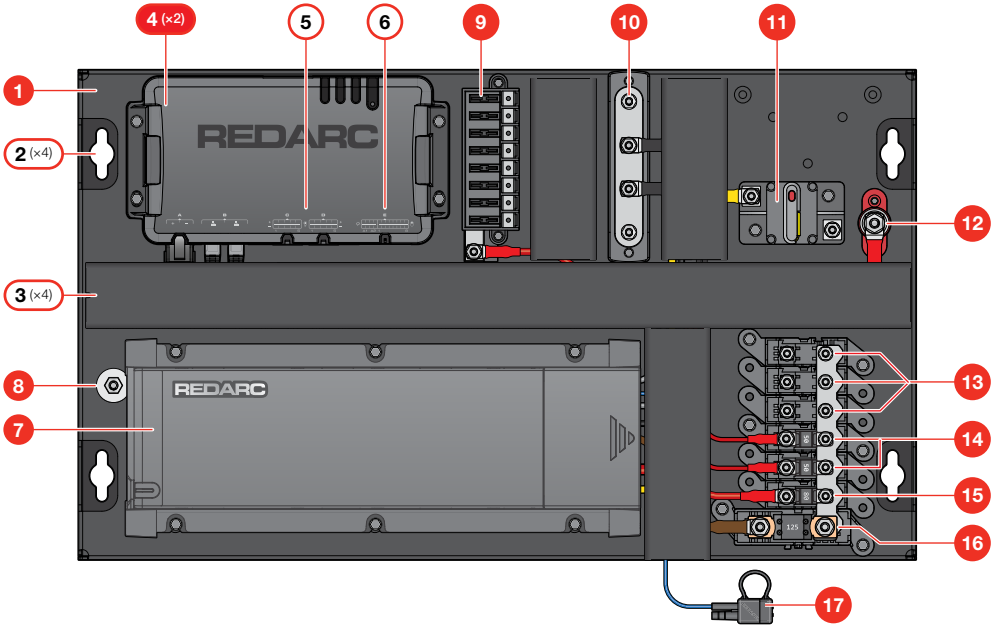

PARTS OF THE ICMS-012

Ref.	Part
1	Mounting Panel
2	Mounting Points x4
3	Cable Ducts (with removable covers)
4	TVMS Rogue x2 (TVMS1240)
5	Outputs Interface C/D (10A outputs)
6	Inputs Interface (Sensor and Switch inputs)
7	Manager Alpha (BMS12050/BMS12075/BMS12100)
8	Earth Grounding Stud
9	Blade Fuse Holder (8 way blade fuse holder with removable cover, not shown)
10	Negative Busbar (with removable cover, not shown)
11	Solar Circuit Breaker
12	Start Battery Connection Point (insulated with cover, not shown)
13	Auxiliary/Spare Fuse Holders
14	TVMS Power Input Fuses (with attached cover, not shown)
15	80A Blade Fuse Holder (with attached cover, not shown)
16	Main Auxiliary Loads Fuse with 125 A MEGA Fuse (fitted) (with attached cover, not shown)
17	Wago® Boot for vehicles with smart alternators

INSTALLATION – MOUNTING

▲ WARNING: Risk of electric shock. Do not expose the ICMS-012 to rain, snow, liquid, or dust. Doing so may result in damage to the ICMS-012 and other appliances installed in the system or result in electric shock or fire.

▲ CAUTION

- Lifting a heavy object can cause muscle strain or back injury. Use lifting aids if needed, and proper lifting techniques when mounting the ICMS-012. If you are not comfortable lifting the ICMS-012 on your own, get somebody to help you.
- Two people are required to safely lift the ICMS-012 above shoulder height.

NOTICE: Do NOT modify the mounting holes in any way. Modification to the unit will void the warranty.

MOUNTING CHECKLIST – BEFORE YOU BEGIN

The ICMS-012 should only be mounted and used in a location that meets the following criteria:

- STRUCTURAL** — Mount only to a fixed, flat, structural surface **using all four mounting holes**. Use appropriate M8 (or 5/16") fasteners (not supplied).
- DRY** — Do not allow water to drip onto or enter the ICMS-012.
- COOL** — Ambient air temperature should be between -20°C and 60°C (-4°F and 140°F).
- SAFE** — Do not install the ICMS-012 in a battery compartment or other areas where volatile fumes may exist, such as fuel storage areas or engine compartments.
- VENTILATED** — Keep the ICMS-012 at a distance at least 50 mm (2") away from surrounding objects. Ensure all ventilation openings are not obstructed.
- DUST-FREE** — Do not install the ICMS-012 in a dusty environment where the dust can enter, and especially cannot be drawn into the fan on the Manager.
- NEAR TO BATTERIES** — Avoid excessive cable runs between batteries and the ICMS-012 to reduce voltage drop across the cables. For safety reasons however, even when installed in a well ventilated area the ICMS-012 should not be installed within 300 mm (12") of a battery. The ICMS-012 must not be installed within the same enclosed compartment as a battery.
- NON-CORROSIVE** — Do not mount the ICMS-012 where it will be exposed to the gasses produced by a battery. These gasses are very corrosive, and prolonged exposure will damage the ICMS-012.
- CORRECT MOUNTING ORIENTATION** — Mounting the ICMS-012 horizontally is ideal, however vertically is acceptable. Do not mount the ICMS-012 upside down.

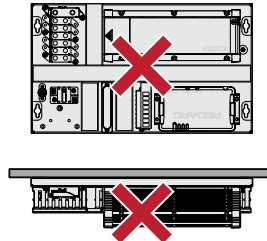
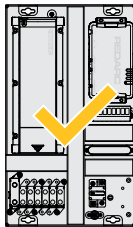
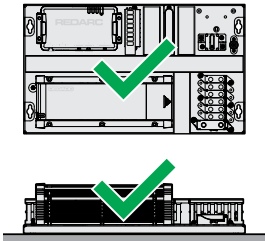

MOUNTING THE ICMS-012

RECOMMENDED FASTENERS

The following fasteners are recommended for secure and safe mounting of the ICMS-012. If you choose to use alternative fasteners, make sure they are equivalent.

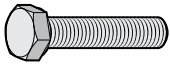

High-tensile bolt × 4

M8 (5/16") – metric class 8.8 or imperial grade 5 minimum. Length determined by mounting surface thickness.



Flat washer × 8

M8 × 16 mm × 1.6 mm (5/16" × 5/8" × 16 gauge) or a max. outer diameter of 25 mm (1").



Mudguard/Fender washer × 4

M8 × 25 mm × 1.6 mm (5/16" × 1" × 16 gauge).



Nylon lock nut × 4

M8 (5/16") – metric class 8.8 or imperial grade 5 minimum.

MOUNTING STEPS

1. Confirm that your chosen mounting location and orientation meets all criteria listed on [page 8](#).
2. Tape the Mounting Template provided on the packaging in the chosen mounting location, making sure the template is completely flat.
3. Use a centre-punch to punch the centre of each mounting point (marked on the template). **Note, all four Mounting Points must be used.** Alternatively, measure and mark the centres of the mounting points.
4. Remove the Template then drill clearance/pilot holes using a 9 mm (23/64") drill bit. De-burr the holes and touch up any bare metal surfaces that have been exposed with a rust-inhibitor (e.g. primer).
5. Fasten the ICMS-012 in place using your chosen fasteners. Get someone to help you lift and position the Unit safely if needed.
6. If using the recommended fasteners, torque to 24.0 N-m/17.7 lbf-ft, or torque appropriately for your chosen fastener grade and vehicle substrate.

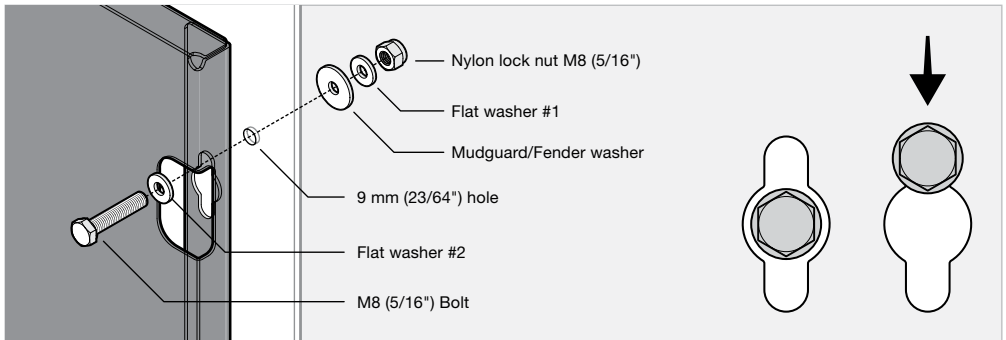

MOUNTING THE DISPLAY AND BATTERY MONITOR

Refer to the Manager Alpha Instruction Manual for mounting instructions for the RedVision Display and Battery Monitor — see 'Full-Length Instruction Manuals' (page 22).

NOTE: The Battery Monitor can be mounted on the top right of the ICMS-012 Panel providing that the Battery Negative cable (B NEG) does not exceed 1 m (3'3").

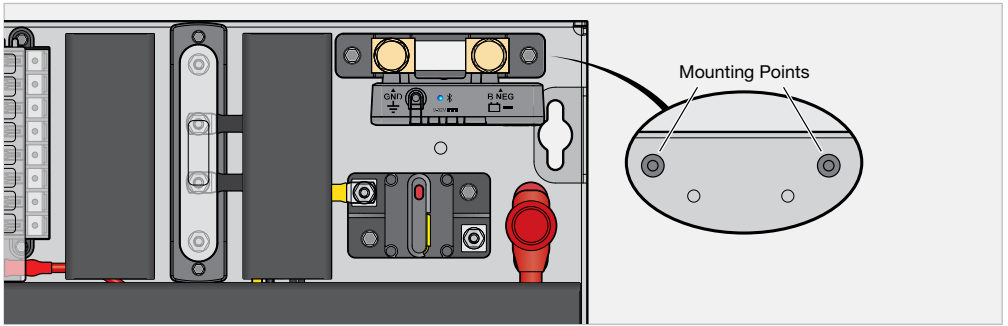

CABLE PASS-THROUGH HOLES

The ICMS-012 Panel features cable pass-through holes, allowing cabling to be routed from behind the panel. These holes are positioned along the centre Cable Duct, allowing a neat and organised installation.

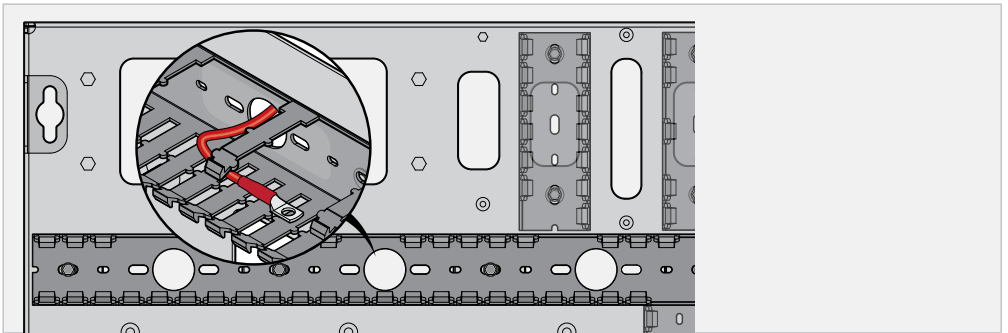

INSTALLATION — WIRING

SYSTEM LAYOUT

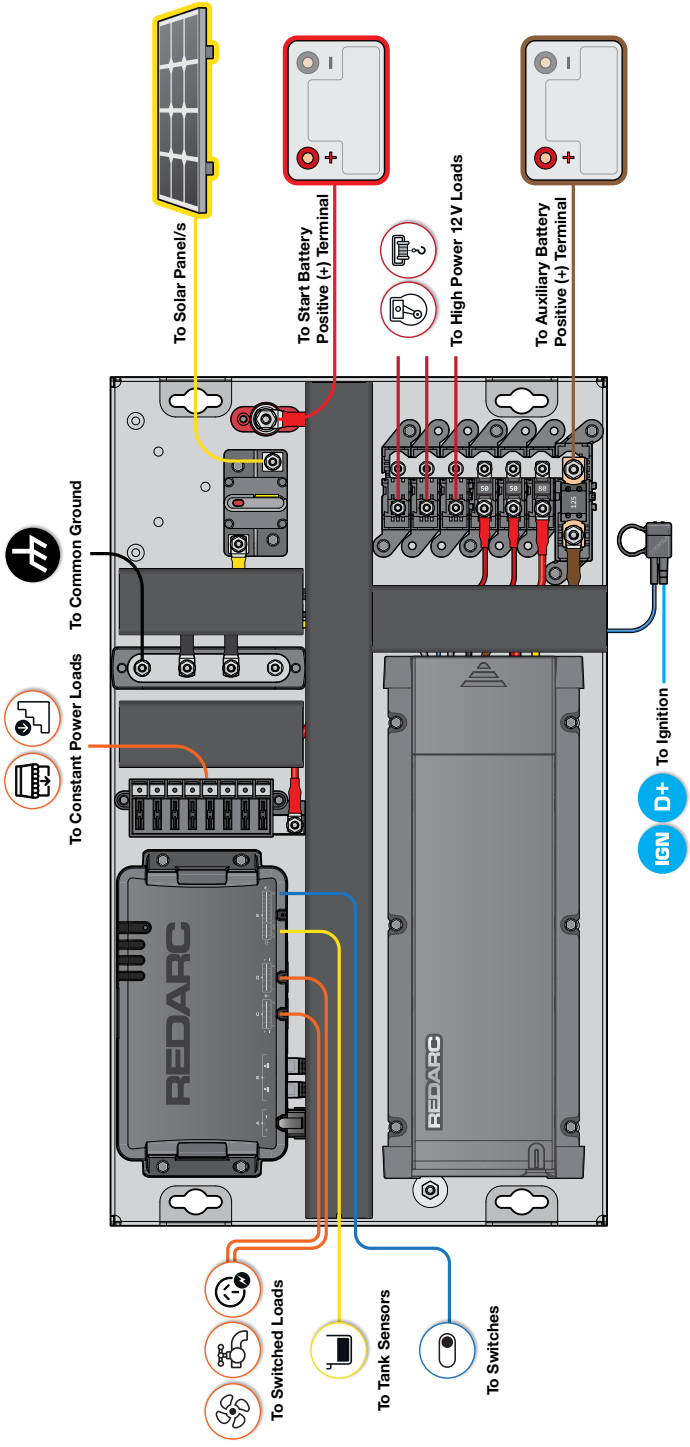

WIRING DIAGRAM – AS SUPPLIED

The following wiring diagram shows the ICMS-012 in its as-supplied state with pre-wired connections, excluding all R-Bus wiring. See [page 16](#) for all pre-wired R-Bus connections.

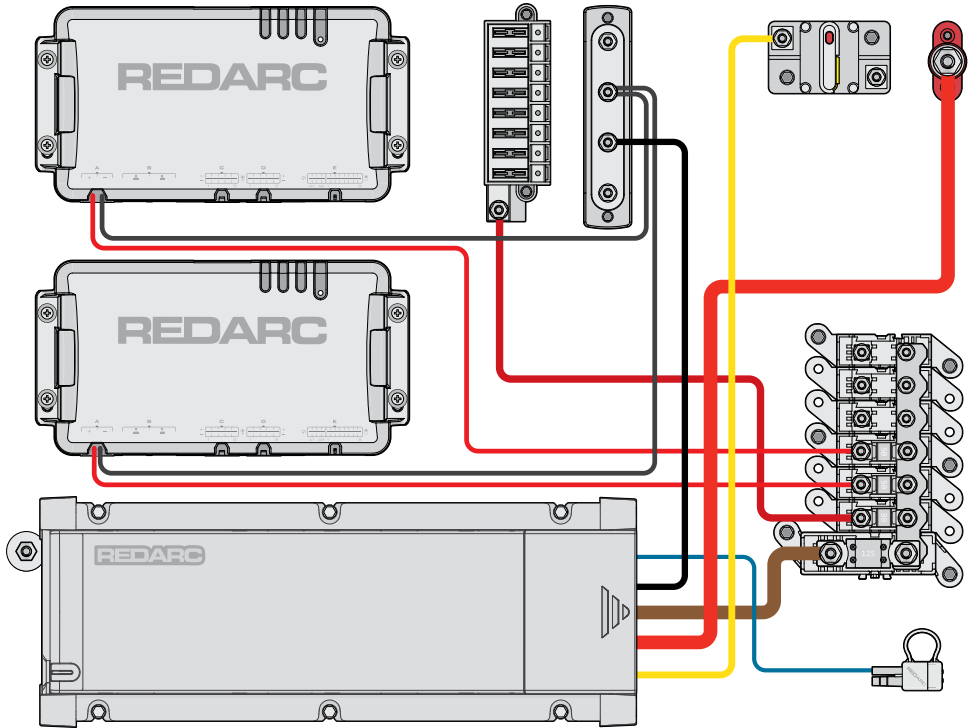

WIRING DIAGRAM – TYPICAL SETUP

The following wiring diagram shows an example of a typical setup.

Blue highlight — cables supplied with the ICMS-012 that require the installer to connect.

Green highlight — devices, cables and related consumables that **need** to be purchased to suit the installation.

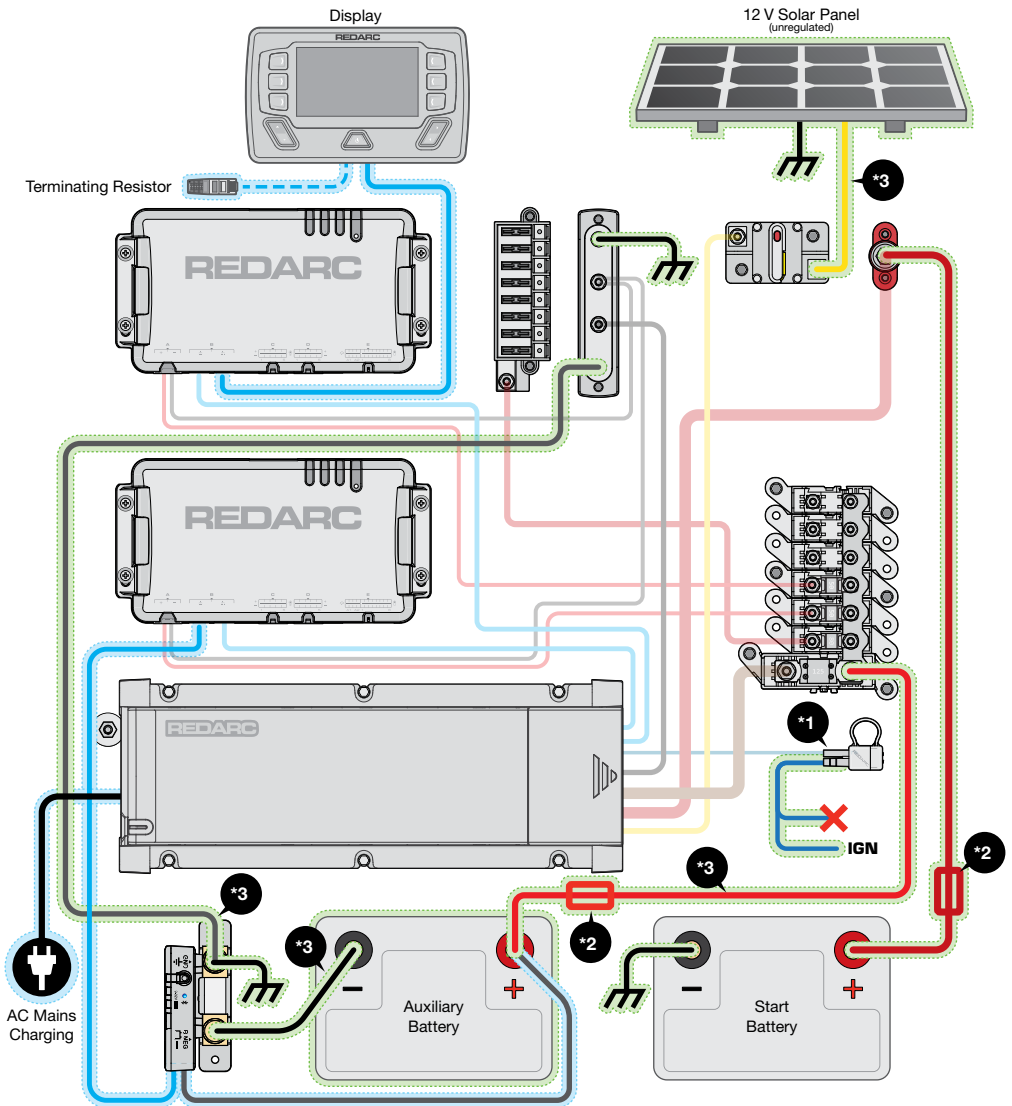

*1 If required, use the Wago® Boot to connect the Manager Alpha to an ignition switched fuse in one of the vehicles fuse boxes, located in either the engine compartment or vehicle cabin - see page 16 for vehicle ignition requirements.

*2 These fuses must be suitably rated for the cable gauge used. REDARC recommends using MEGA type fuses.

*3 Refer to the full-length Manager Alpha and Battery Monitor manual for lug, cable and fuse sizing — see 'Full-Length Instruction Manuals' (page 22).

WIRING STEPS

▲ CAUTION: Selecting the wrong cable or fuse size could result in harm to the installer or user and/or damage to the battery or other equipment installed in the system. The installer is responsible for ensuring that all installer supplied cables and fuses are the correct size and type (i.e. has physical performance properties and ratings suitable for the install conditions).

WHAT YOU WILL NEED

Before you begin, purchase the correct cable sizes, lugs, fuses, and consumables needed for your installation.

Note: Poor quality cables can degrade over time posed to high temperatures (such as in an engine bay). Make sure you purchase good-quality cables with a suitable temperature rating for your installation.

You will need to source suitably rated cables for the following connections:

- Battery Monitor terminal connections — see [step 1 \(page 14\)](#).
- Auxiliary battery positive (+) connection — see [step 1 \(page 14\)](#)
- Negative Busbar to chassis ground connection — see [step 2 \(page 15\)](#)
- Start battery positive (+) connection — see [step 3 \(page 15\)](#)
- Vehicle ignition connection (applies to vehicles with variable-voltage alternators) — see [step 4 \(page 16\)](#)
- Solar panel connection — see [step 6 \(page 17\)](#)
- Auxiliary loads connections — see [step 7 \(page 17\)](#)

Refer to the Battery Monitor and Manager Alpha manual for important installation instructions and appropriate cable and lug sizing — see [page 22](#).

1. CONNECT THE AUXILIARY BATTERY

▲ CAUTION: The auxiliary battery positive (+) connection must be made to the M8 125A MEGA Fuse. DO NOT connect the auxiliary battery to the low current fuses (80A and 50A Fuses).

Purchase lugs, cables and a MEGA fuse that is the same or greater size than the Auxiliary Loads Fuse on the ICMS-012 (125A) for your installation.

- 1.1 Connect a cable to BNEG terminal on the Battery Monitor and to the negative (-) terminal on the auxiliary battery.
- 1.2 Mount the MEGA fuse close to the auxiliary battery (no more than 150 mm (6") in cable length).
- 1.3 Connect a cable to one end of the Auxiliary Loads Fuse on the ICMS-012 and to the MEGA fuse. Torque the terminal bolt on the Auxiliary Loads Fuse to 12N·m (8.85 lbf·ft) using a 13 mm (1/2") hex head socket driver.
- 1.4 Connect a cable to the other end of the MEGA fuse and to the positive (+) terminal of the auxiliary battery.
- 1.5 Insert the Connector on the Battery Sense Lead into the B POS socket on the Battery Monitor, then connect the Battery Sense Lug to the auxiliary battery positive (+) terminal.
- 1.6 Connect a cable to the GND terminal on the Battery Monitor and to the chassis ground.

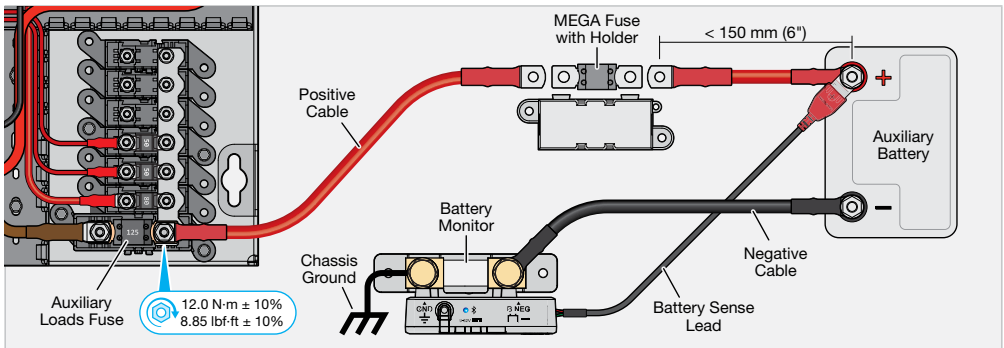

2. CONNECT THE NEGATIVE BUSBAR TO CHASSIS GROUND

Purchase a cable rated to carry the maximum charge current and lugs suitable for the Negative Busbar stud (6 mm (1/4")) and chassis ground connection point.

- 2.1 Connect the cable between the Negative Busbar and the vehicle common ground (usually vehicle metal body).
- 2.2 Using a hex driver, torque the terminal nut on the Negative Busbar to 6.8 N-m (5 lbf-ft).

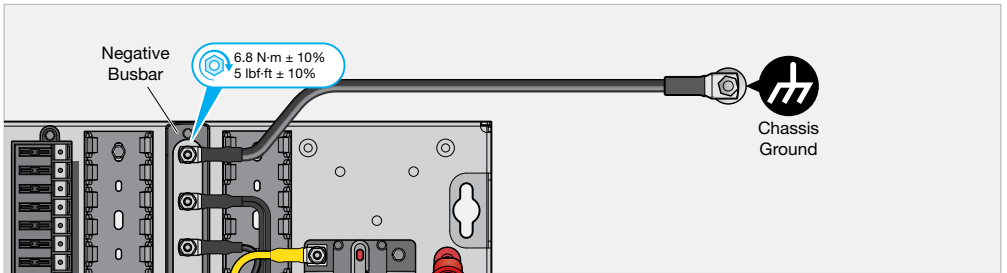

3. CONNECT THE START BATTERY

Purchase the correct lug, cable size and a MEGA fuse size needed for your installation, and an M8 lug for the Start Battery Connection Point on the ICMS-012.

- 3.1 Mount the MEGA fuse close to the start battery (no more than 150 mm (6")) in cable length).
- 3.2 Connect a cable to the M8 Start Battery Connection Point and to the MEGA fuse. Torque the M8 Stud on the ICMS-012 to 12 N-m (8.85 lbf-ft) using a 13 mm (1/2") hex head socket driver.
- 3.3 Connect a cable to the other end of the MEGA fuse and to the positive (+) terminal of the start battery.

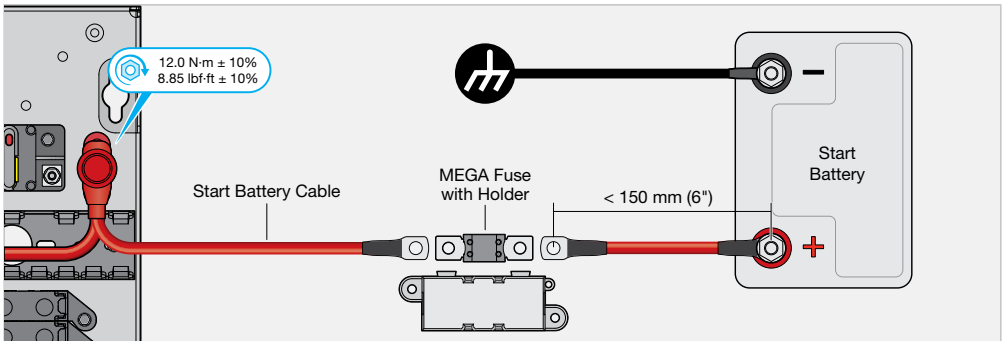

4. CONNECT IGNITION

The Ignition wire is used to turn the DC charging source on with ignition via the Wago® Boot. This feature allows vehicles with variable-voltage alternators to trigger the DC Input. This feature must be activated via the RedVision Display in the 'BMS Settings' screen.

4.1 Depending on your vehicle's alternator type, connect ignition:

- **Fixed-voltage alternator (standard alternator)** — do not connect.
- **Variable-voltage alternator (smart alternator)** — connect to a point that is live only when the ignition is turned on (A).
- **Idle-stop vehicles** — connect the vehicle ignition wire to D+ or engine-running signal (B).

4.2 Unlock the terminal lever on the Wago® Splice then route a stripped wire through the spare Leg of the Wago® Boot and into the terminal on the Wago® Splice. The Leg can be trimmed to fit larger thicker wire up to 2.7 mm/0.3" in diameter (10 AWG/5.26 mm²).

4.3 Lock the terminal lever on the Wago® Splice and wrap electrical tape around the Wago® Boot to secure the lid and protect against water entry.

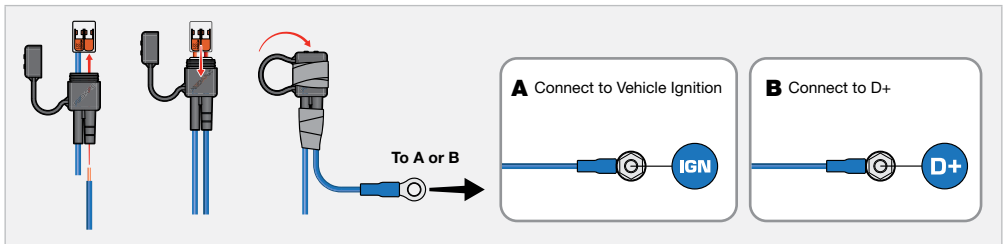

5. CONNECT R-BUS CABLES

The Battery Monitor and Display need to be connected to the RedVision system using the supplied R-Bus cables. The Manager and both TVMS's R-Bus connections are pre-wired on the ICMS-012 board.

The blue cables highlight require wiring to complete the RedVision system using the supplied R-Bus cables.

- 5.1 Plug one R-Bus cable into the Battery Monitor 'RBUS' socket and into one of the R-Bus sockets on the TVMS.
- 5.2 Plug the other R-Bus cable into the RedVision Display and into the other TVMS's R-Bus sockets.
- 5.3 Plug the supplied Terminating Resistor into the other R-Bus socket on the rear of the Display.

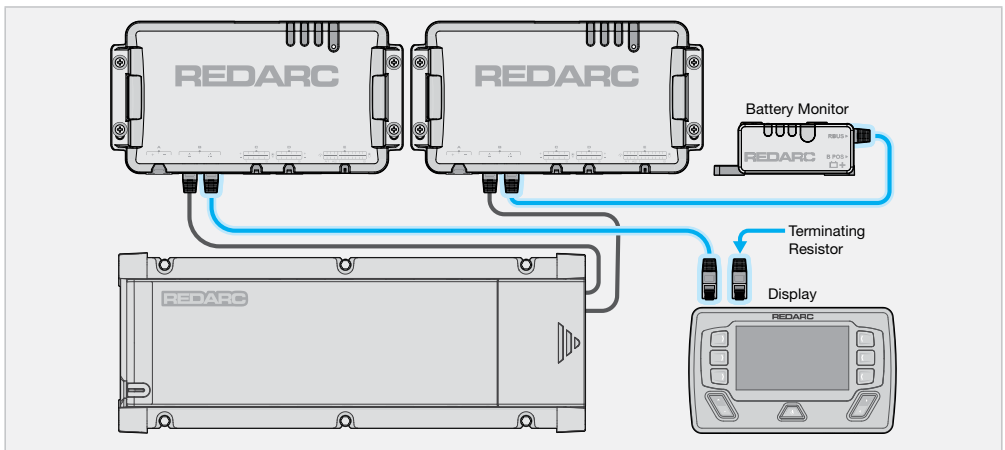

6. CONNECT SOLAR

Refer to the supplied Manager Alpha Instruction Manual for solar specifications, limits and cable sizing before making any solar connections — see [page 22](#).

Purchase the correct cable size and connector type for your solar and ground connection, and an M6 lug for the Solar Circuit Breaker connection on the ICMS-012.

6.1 Connect Solar Positive cable to the Solar Circuit Breaker using an M6 lug. Torque to 5.3 N-m (3.9 lbf-ft).

6.2 Depending on your setup, connect Solar Negative cable to either of the following:

- A vehicle chassis ground point (**A**), or;
- The Negative Busbar (**B**). Using a hex driver, torque the nut on the Negative Busbar to 6.8 N-m (5.0 lbf-ft).

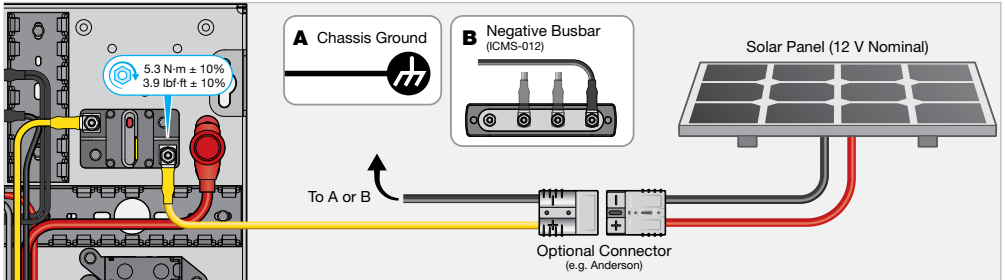

7. CONNECT AUXILIARY LOADS

TVMS ROGUE LOADS

Suitable for typical loads up to a maximum of 10A per channel.
Refer to the TVMS Rogue manual for further information — see [page 22](#).



8 WAY BLADE FUSE HOLDER

Suitable for loads up to 30 A that require constant power such as an electric awning and electric RV steps.



AUXILIARY / SPARE FUSES

Suitable for loads between 30 A to 100A such as an air compressor and electric jacks.

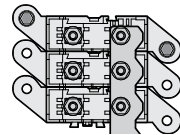

CONNECTING AN INVERTER

The Remove Control Terminal on REDARC Inverters allows an Output from the TVMS Rogue to act as an on/off switch for the inverter.

To connect a REDARC RS3 Inverter into the ICMS system:

1. Connect the Chassis Ground to the same common ground connection point of the system.
2. Connect the Negative DC Input cable to the GND terminal on the Battery Monitor.
3. Connect the Output Wiring Loom into the Output C or D on the TVMS Rogue.
4. Connect an Orange wire on the Output Wiring Loom to the **ENB+** input on the Inverter.
5. Insulate the end of the unused, like-numbered Black wire to prevent it from shorting.

Refer to the RS3 Inverter manual for important installation instructions and cable sizing — see [page 22](#).

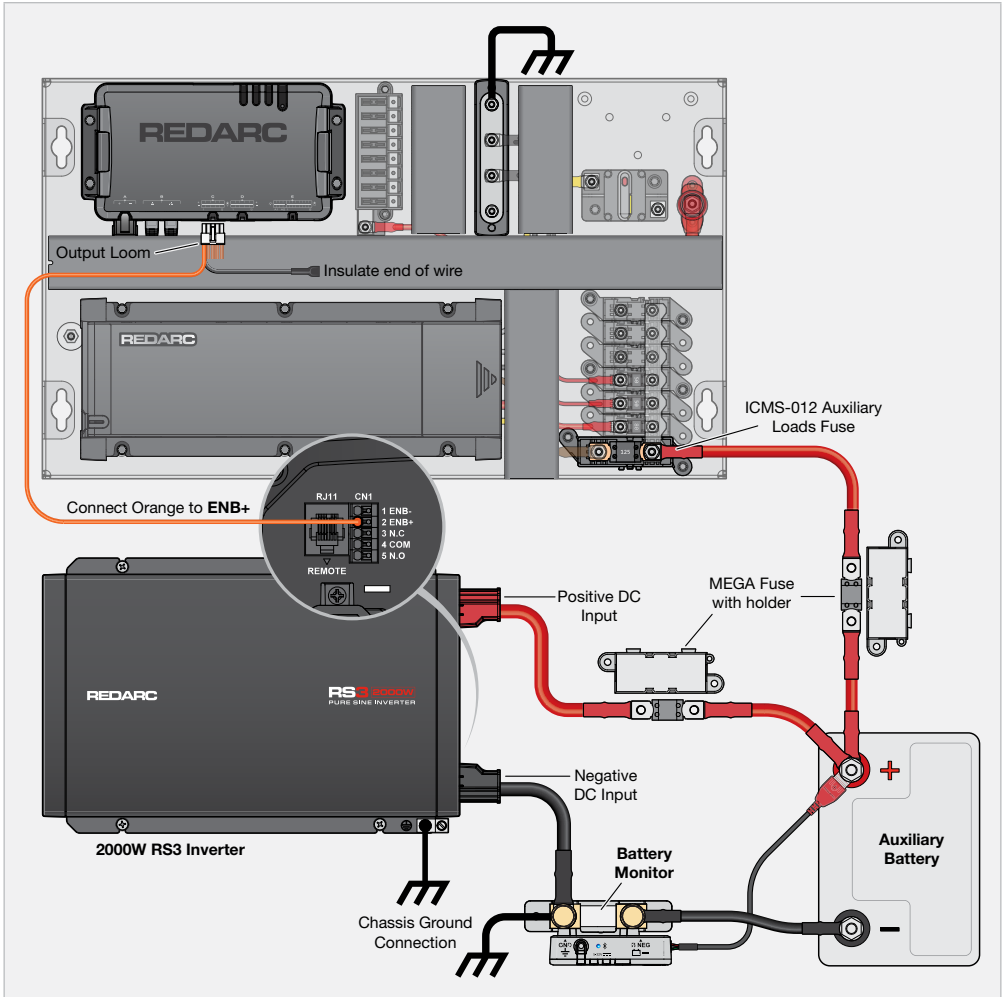

CONNECTING TANK LEVEL SENSORS

Up to 4 tank level sensors can be connected to the TVMS Rogue for measuring tank levels including grey water or clean water tanks. REDARC's Tank Level Sensors are recommended.

1. Connect the Input Wiring Loom into the Input Interface on the TVMS.
2. Connect the wires from the tank-level sensor to a numbered pair of Yellow and Green on the Input Wiring Loom (at E A1 or A2).
3. Insulate the ends of the individual unused wires (like-numbered Red and Black wires) to prevent them from shorting. DO NOT heatshrink/tape multiple unused wires together as a single bundle.

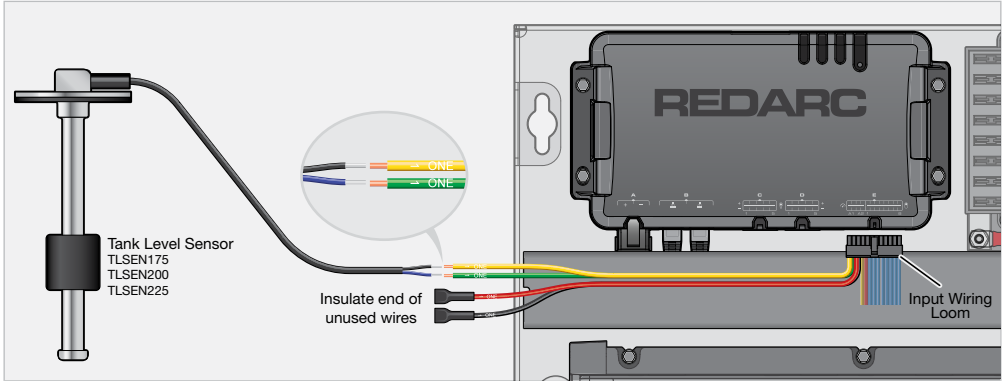

CONNECTING TO SWITCHES

The TVMS Rogue has 16 digital inputs that can be configured to switch output loads on and off when triggered, for example to turn off all loads except a fridge when the vehicle ignition is on.

1. Connect the Input Wiring Loom into the Input Interface on the TVMS.
2. Connect the wires from the Switch to a numbered pair of Blue and Grey wires on the Input Wiring Loom.
3. Insulate the ends of the individual unused wires to prevent them from shorting. DO NOT heatshrink/tape multiple unused wires together as a single bundle.

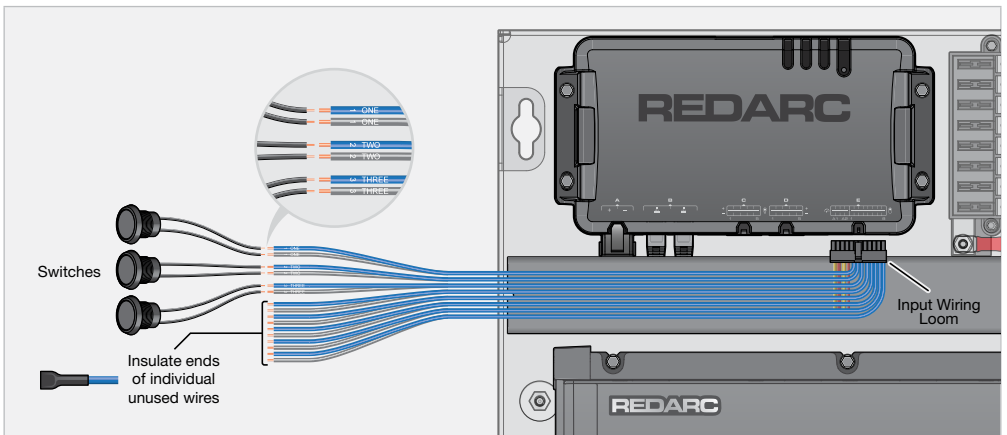

8. CONFIGURATION AND TESTING

Refer to the Manager Alpha and TVMS Rogue manual for configuration information — see [page 22](#). This step is important to configure your battery type, capacity, and more. Once configured, test the system to make sure it is operating safely and correctly.

TVMS ROGUE STRAIN-RELIEF AND CABLE MANAGEMENT

⚠ CAUTION: Do not route cables over hot surfaces and sharp objects, or over/through parts of the vehicle that move during operation or maintenance.

COUPLING THE LOOM CONNECTORS

Ensure all cables/loom connectors are firmly coupled. Cables must be firmly secured to the Panel and routed so that they are not pushing or pulling on the connector interfaces in the TVMS Rogues. Internal components and connectors may become damaged if they are subjected to repeated strain/vibration due to inadequate cable restraint.

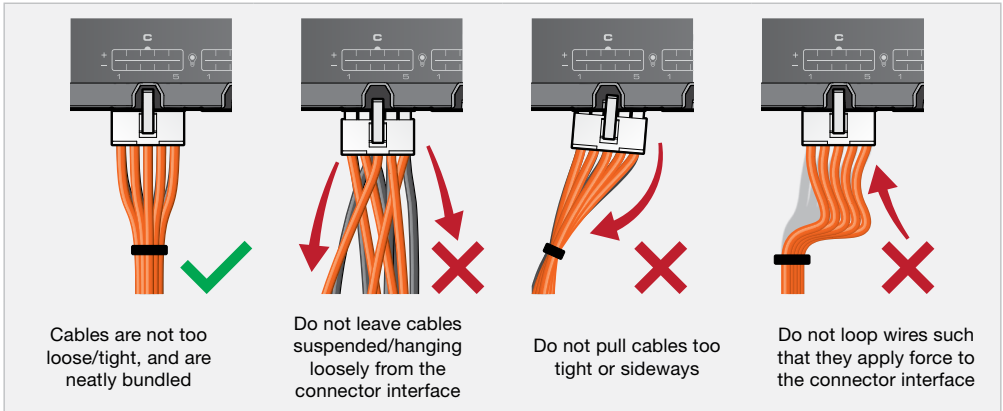

PROTECT AND SECURE THE CABLES

Secure the TVMS Rogue cables to the Cable Tie Mounting Blocks along the centre Cable Duct on the Panel using cable ties. Ensure the cables are secured along the bottom of the Cable Duct so the cables aren't pulled or stretched tightly as demonstrated below.

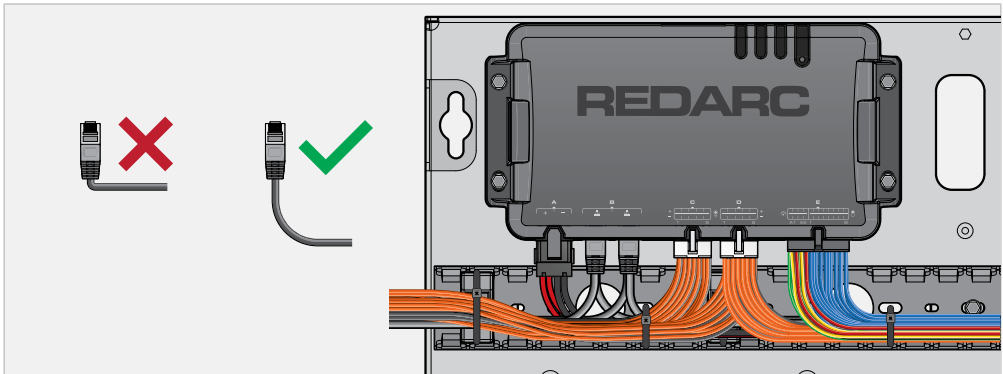

SYSTEM STRAIN-RELIEF AND CABLE MANAGEMENT

⚠ CAUTION: Do not route cables over hot surfaces and sharp objects, or over/through parts of the vehicle that move during operation or maintenance.

PROTECT AND SECURE THE CABLES

Once all wiring is completed, do the following to protect and secure the cables:

- Route all cabling through the Cable Ducts where possible.
- Use cable ties to secure bundled cables to the Cable Tie Mounting Blocks within the ducting (see below).
- Flexible conduit (not supplied) can be used to manage and protect bundled cables.
- Make sure all removable covers on the fuses and fuse box are put back on once wiring is complete.

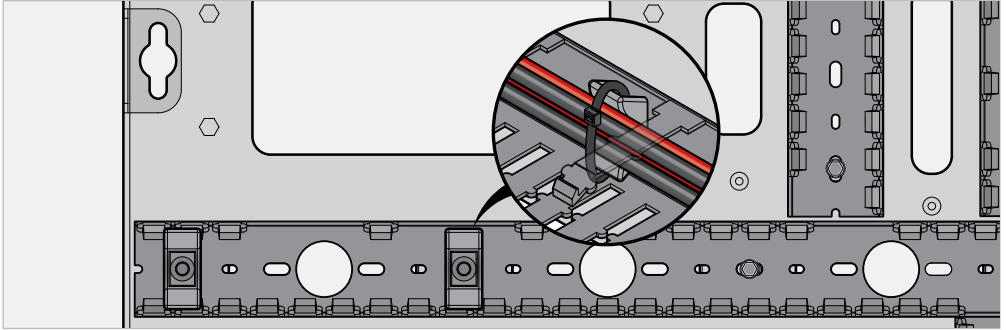

PREVENTING WATER ENTRY

Add a drip-loop to any cables connecting to the ICMS-012. Ensure the drip-loops are made outside the ICMS-012 to prevent moisture from running down the cables into sockets/terminals and devices.

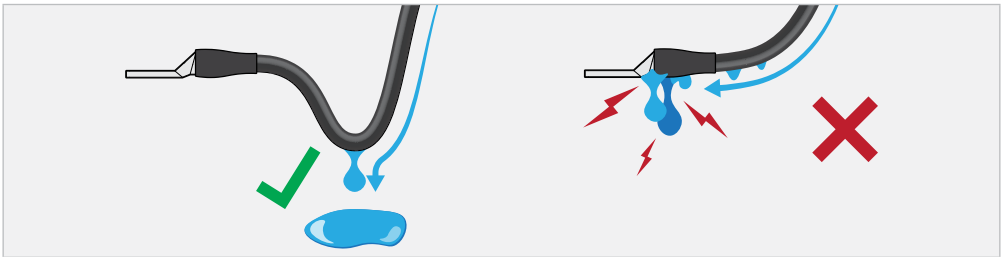

FULL-LENGTH INSTRUCTION MANUALS



Battery Monitor
full-length Manual



Manager Alpha
full-length Manual



TVMS Rogue
full-length Manual



RS3 Inverter
full-length Manual

TECHNICAL SPECIFICATIONS

Specifications subject to change without notice.

PHYSICAL SPECIFICATIONS

Weight	14.9 kg (32.8 lb)
Dimensions	650 × 380 × 145.8 mm (25.6" × 15" × 5.74")

THERMAL SPECIFICATIONS

Ideal Operating Temperature Range	-20 ~ +40°C / -4 ~ +104°F
--	---------------------------

BLADE FUSE HOLDER SPECIFICATIONS

Circuits	8
Maximum Amperage*4	100 A, 30 A per circuit
Maximum Voltage	32 V DC
Screw Terminal Stud Size	#8-32 screws with captive star lock washer
Screw Terminal Torque	2.03 N·m (1.5 lbf·ft)
Screw Terminal Driver Type	PH2/#2

*4 Maximum amperage ratings are dependant on the use of appropriately sized fuses and wire for the given application.

WARRANTY

LIMITED WARRANTY

For full warranty terms and conditions, visit the Warranty page of the REDARC website:

www.redarcelectronics.com/warranty

Australia, New Zealand, UK & Europe

REDARC Electronics Pty Ltd
23 Brodie Road (North), Lonsdale SA
5160, Australia

Australia 1300-733-272
New Zealand +64 9 222 1024
UK & Europe +44 (0)20 3930 8109

North America

REDARC Corporation
c/o Shallco, Inc., 308 Component Dr., Smithfield, NC
27577, USA

USA +1 (704) 247-5150
Canada +1 (604) 260-5512
Mexico +52 (558) 526-2898

IMPORTER CONTACT INFORMATION

UK: Ozparts UK Ltd, 1 Prospect Place, Pride Park, DE24 8HG, Derby, UK

Europe: Ozparts Sp. z o. o. Sp. kom., Slowackiego 32/5, 87–100 Torun, Poland

For written request please email power@redarcelectronics.eu

CHECKING THE PRODUCT SERIAL NUMBER

The Product Serial Number label is located on the product and on the product packaging.

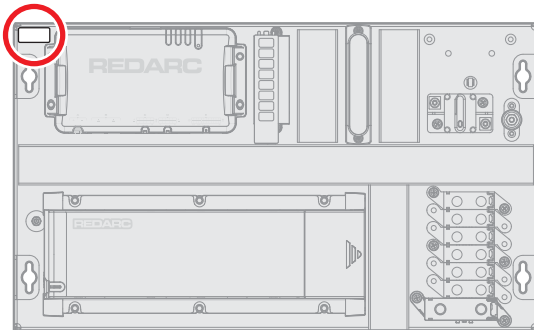

Tech Support

1300 REDARC (1300-733-272)

Australia

+61 8 8322 4848

New Zealand

+64 9 222 1024

UK & Europe

+44 (0)20 3930 8109

USA

+1 (704) 247-5150

Canada

+1 (604) 260-5512

Mexico

+52 (558) 526-2898

redarcelectronics.com

THE POWER OF

