



**DAVEY**

## **DAVEY** XF Series

**GUARANTEE**  
2 YEARS

**MODEL NUMBERS:**  
XF92, XF171, XF221 & XF192

**PART NUMBERS:**  
71401, 71101, 71201 & 71301

### **APPLICATIONS**

Ideal for pumping clean, non-volatile liquids without fibres or solids in such applications as irrigation, aquaculture, water transfer, washing systems and hydroponics.

### SINGLE OR TWIN STAGE ELECTRIC TRANSFER PUMP

### FEATURES & BENEFITS

- **Designed for total head duties to 33m and flows to 225 lpm**
- **Also available in 220 Volt 60Hz single phase**
- **Davey manufactured TEFC IP55 motor is corrosion resistant and resists low pressure jets of water, dust and dirt for long service life in arduous conditions**
- **Closed vane corrosion proof impellers with full length "D" drive for positive, robust impeller drive.**
- **Motor and pump are designed for frequent starts providing a long and reliable working life.**
- **Pump shafts (and casing on two stage models) are manufactured from quality corrosion resistant stainless steel for long service life when pumping less than perfect water.**
- **Every pump is performance and pressure tested in our factory to ensure quality and reliability.**
- **All models come fitted with a 2m power lead with 10 amp Australian three pin plug for ease of connection to power supply.**
- **High quality mechanical shaft seal for long life and reliability.**
- **Easy to service design for shorter downtime** if or when service is required.
- **Permanently split capacitor design motor** for reliable starting even in low voltage circumstances.
- **Double contact C3-HTG sealed bearings** for quieter running and longer life.
- **In-built automatic-reset thermal overload protection embedded in the motor for quick response to motor overloading.** Motor overloading can be the result of extreme ambient temperature, high or low voltage (beyond specification), pump blockage and / or pumping fluids heavier than fresh water (e.g. sea water).
- **Plastic feet used on motor shell** for long life in poorly drained installations.

# Transfer Pumps



OPERATING LIMITS				
Model	XF92	XF171	XF221	XF192
Capacities to	98 lpm	175 lpm	225 lpm	190 lpm
Maximum total head	28m	17m	20m	33m
Maximum suction head	7.0m	7.5m	7.5m	7.5m
Maximum water temperature	50°C			
Minimum water temperature	1°C			
Maximum ambient temperature	50°C			
Inlet size	1" BSP(F)			
Outlet size	1" BSP(F)	1" BSP(M)	1" BSP(M)	1" BSP(F)

MATERIALS OF CONSTRUCTION	
PART	MATERIAL
Impellers (XF92 & XF192 have 2)	Glass filled polycarbonate
Lock nut	304 stainless steel
Pump casing - XF171 & XF221 - XF92 & XF192	Glass filled noryl 304 stainless steel
Suction cover	Glass filled noryl
Clamp band	304 stainless steel
Pump shaft	304 stainless steel
Seal ring (stationary)	Ceramic
Seal ring (rotating)	Carbon
Seal spring	304 stainless steel
O-rings	Nitrile rubber
Diffusers	Glass filled noryl
Blanking ring - XF92 & XF192	Glass filled noryl
Spacer	Glass filled nylon
Priming plug	Glass filled noryl
Motor shell	Marine grade aluminium
Shell finish	Baked polyester

INSTALLATION AND PRIMING
<ul style="list-style-type: none"> <li>Installation with suction lift require a good quality foot valve to avoid loss of prime.</li> <li>To prime, fill pump body and suction line through priming plug hole located above suction inlet and replace plug.</li> </ul>

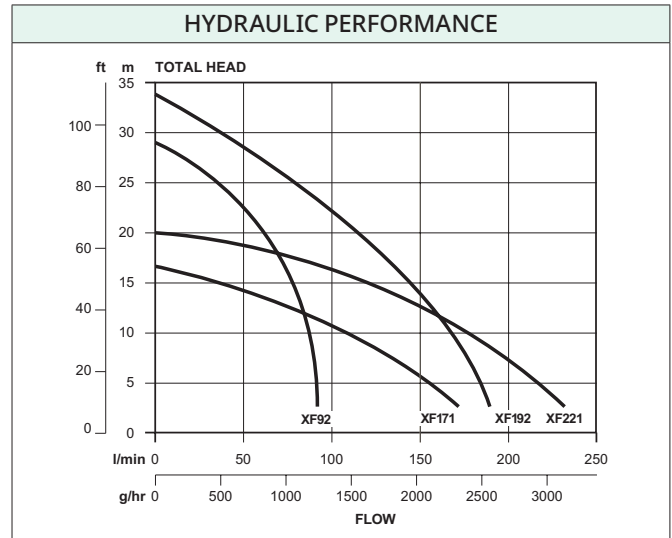

ELECTRICAL DATA				
Model	XF92	XF171	XF221	XF192
Phase	Single			
Supply voltage	220-240V ±6%			
Supply frequency	50Hz			
Speed	2,850 rpm			
Full load current	3.7A	2.8A	4.5A	5.2A
Locked rotor current	12.0A	12.0A	18.0A	18.0A
Input power (P <sub>1</sub> )	0.84kW	0.78kW	1.05kW	1.15kW
Output power (P <sub>2</sub> )	0.58kW	0.53kW	0.70kW	0.80kW
Enclosure	IP55			
Insulation	Class F			
Starting	P.S.C.			

**Special Models**  
 XF models are available in a number of alternate voltages and incorporating special features including:

- 220 volt 60Hz
- Silicon Carbide Seals
- Dog Spa Model
- Thermotection pump over temperature protection

For information of these options contact Davey.

DIMENSIONS (mm)										
Model	A	B	C	D	E	F	Mounting holes diameter (mm)	Inlet B.S.P.	Outlet B.S.P.	Net Weight (kg)
XF92	325	220	195	100	125	100	10 @ 140 centres	1" F	1" F	7.2
XF171	325	215	193	100	126	100		1" F	1" M	6.7
XF221	350	215	193	100	126	100		1" F	1" M	8.3
XF192	350	220	195	100	125	100		1" F	1" F	8.8

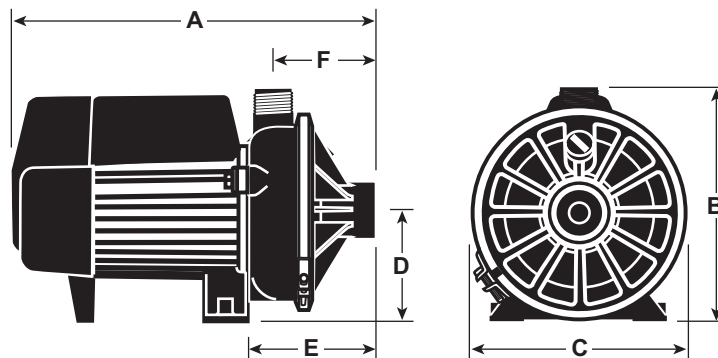

[daveywater.com](http://daveywater.com)

This literature is not a complete guide to product usage. All images provided in this document are for illustration purposes only. Further information is available from your Davey Dealer, Davey Support Centre and from the relevant product Installation and Operating Instructions. Must be read in conjunction with the relevant product Installation and Operating Instructions and all applicable statutory requirements. Product specifications may change without notice. © Davey is a registered trademark of Davey Water Products Pty Ltd. © Davey Water Products Pty Ltd 2024.

